

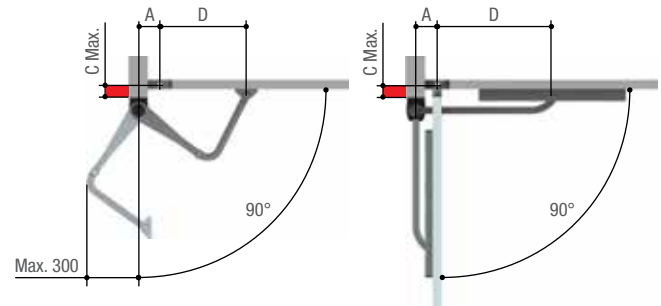

Ideal solution to fit onto small gate posts

- Encoder-based movement control.
- Tested in compliance to parameter established by the current norms.
- Can be installed onto gates with posts just 8 cm wide, and up against a wall or fence, thanks to the straight slide-arm option.
- It works in emergency mode during blackouts.
- Reliable and sturdy even if small, thanks to the system's self-locking mechanism.
- Release system with customised key.
- Reversible version also available.

Dimensions (mm)

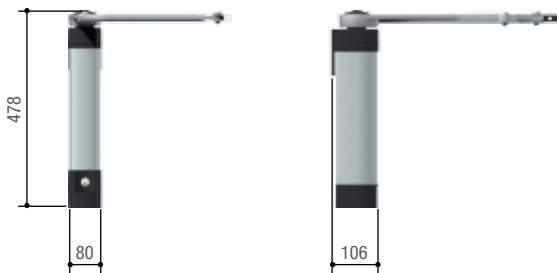

Dimensions of application (mm)

ARTICULATED ARM GATE-LEAF OPENING	STYLO-BS		
	A	D	C Max.
90	90	450	0
90	90	450	180
90	130	450	180
120	170	450	0

STRAIGHT ARM GATE-LEAF OPENING	STYLO-BD		
	A	D	C Max.
90	90	400	0
90	90	400	40
90	90	400	150
90	90	400	180
90	90	400	200
90	230	300	180
135	230	300	0

Limits to use

MODELS	STYLO-ME • STYLO-RME		
Max leaf length (m)	1.8	1.2	0.8
Max leaf weight (kg)	100	125	150
Max gate-leaf opening (°)	120 (with STYLO-BS) - 135 (with STYLO-BD)		

Technical features

MODELS	STYLO-ME • STYLO-RME		
Protection rating (IP)	54		
Power supply (V - 50/60 Hz)	230 AC		
Motor power supply (V)	24 DC		
Current draw (A)	5 Max.		
Power (W)	48		
90° manoeuvre time (s)	ADJUSTABLE		
Duty cycle (%)	INTENSIVE SERVICE		
Torque (Nm)	100		
Operating temperature (°C)	-20 ÷ +55		
Motor thermo-protection (°C)	-		