

CE

For industrial
sliding doors



Tub

Instructions and warnings for the fitter



- Do not modify any components unless such action is specified in this manual.
Operations of this type are likely to lead to malfunctions. NICE disclaims any liability for damage resulting from modified products.
- During installation and use, ensure that solid objects or liquids do not penetrate inside the control unit or other open devices. If necessary, please contact the NICE customer service department; the use of TUB3500 in these conditions can be dangerous.
- The automation system must not be used until it has been commissioned as described in chapter 5: "Testing and commissioning".
- The packing materials of TUB3500 must be disposed of in compliance with local regulations.
- If a fault occurs that cannot be solved using the information provided in this manual, refer to the NICE customer service department.

- In the event that any automatic switches are tripped or fuses blown, you must identify the fault and eliminate it before resetting the switches or replacing fuses.
- Before accessing the terminals within the TUB3500, disconnect all power supply circuits, by means of the magneto-thermal switch for example on the control unit.

2) Product description and intended use

The TUB3500 is a sliding gate gear motor of significant dimension for industrial use, with built-in control unit and is also prearranged for the inclusion of NICE receivers.
The gear motor, which functions electrically, can be disengaged by means of a key, thereby allowing the gate to be opened manually.

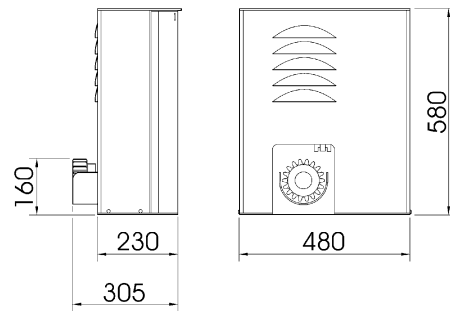

1

2.1) Operating limits

The data relating to the performance of the TUB3500 are indicated in chapter 7 "Technical characteristics" and are the only values that allow the use capabilities to be correctly evaluated.
In general, TUB3500 is suitable for the automation of gates up to 3500 Kg or up to 30 m in length following that indicated in table 1.

Table 1: limits in relation to the length of the leaf

Length of leaf in metres	Maximum cycles/hour
Up to 5	30
5÷10	15
10÷15	10
15÷20	7
20÷25	6
25÷30	5

2.2) Typical system

The figure below indicates a typical sliding gate automation system using the TUB3500.

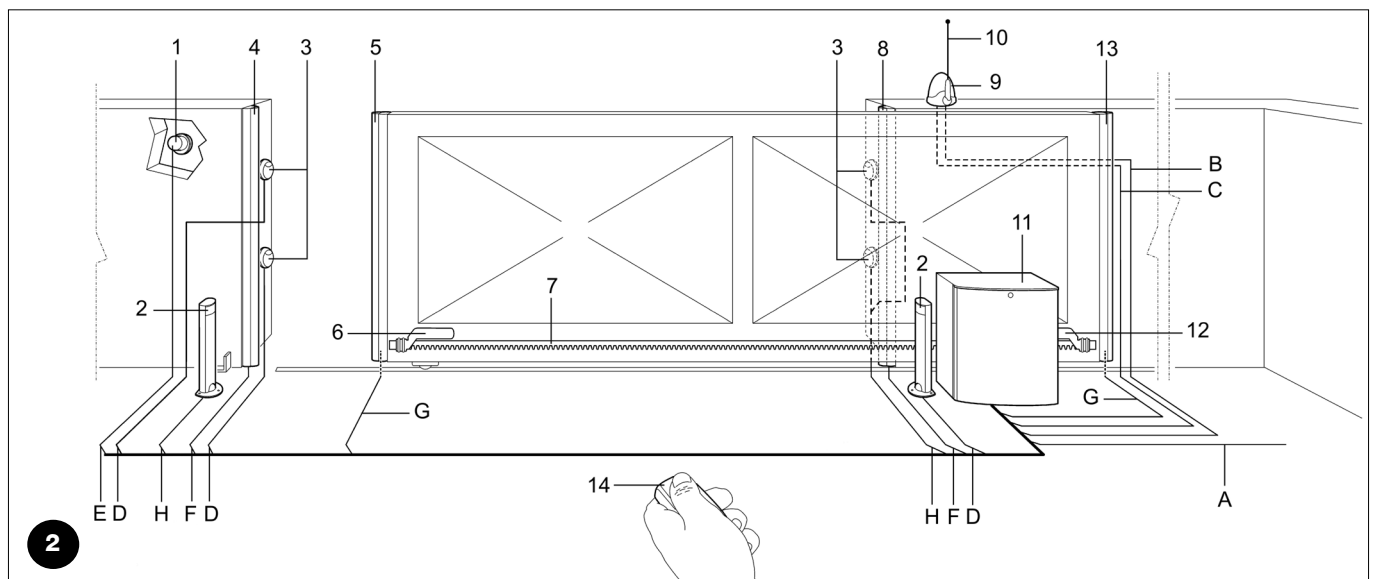

2

- | | | |
|---------------------------------|------------------------------------|--|
| 1. Key operated selector switch | 6. "Open" stop bracket | 11. Motor |
| 2. Photocell on post | 7. Rack | 12. "Closed" stop bracket |
| 3. FOTO photocells | 8. Secondary fixed edge (optional) | 13. Secondary moveable edge (optional) |
| 4. Main fixed edge (optional) | 9. Flashing light | 14. Radio transmitter |
| 5. Main moveable edge | 10. Aerial | |

2.3) List of cables

Figure 2 shows the cables needed for the connection of various devices in a typical installation; Table 2 shows the cable characteristics.

⚠ The cables used must be suitable for the type of installation. For example, an H05VV-F type cable is recommended for indoor applications or an H07RN-F if fitted externally.

Table 2: List of cables

Connection	Cable type	Maximum length allowed
A. Power line	1 - 4x1.5mm ² cable	30 m (1)
B. Flashing light	1 - 2x1.5mm ² cable	20 m
C. Aerial	1 RG58 type shielded cable	(recommended less than 5 meters)
D. Transmitter photocells	1 - 2x0.25mm ² cable	30 m (3)
E. Key operated selector switch	2 - 2x0.25mm ² cables	50 m (2)
F. Fixed edges	1 - 2x0.5mm ² cable	30 m (4) (6)
G. Moveable edges	1 - 2x0.5mm ² cable	30 m (4) (5) (6)
H. Receiver photocells	2 - 2x0.25mm ² cables	30 m (2) (3)

Note 1: Power supply cables longer than 30 m may be used provided they have a larger gauge, e.g. 4x2.5mm², and a safety earthing system is provided near the automation unit.

Note 2: A single 4x0.25mm² cable can be used instead of two 2x0.25mm² cables.

Note 3: Use shielded cables if the length exceeds 30 m, connecting the braid to earth only on the control unit side

Note 4: Several safety edges may be necessary in particular applications. See the instructions manual for the advised type of connection if there is more than one edge.

Note 5: Special devices which enable connection even when the leaf is moving must be used to connect movable edges to sliding leaves.

Note 6: The necessary number of conductors to connect the moveable and fixed edges depends on the method used to guarantee the required safety category. The example refers to the TCB65 edges connected to the TCE interface.

3) Installation

⚠ Installation of the TUB3500 must be performed by qualified technical personnel only, in compliance with current legislation, standards and regulations, and that provided in the present instructions.

3.1) Preliminary checks

The following controls must be performed before proceeding with the installation of the TUB3500:

- Check that all the materials are in excellent condition, suitable for use and that they conform to the standards currently in force.
- Make sure that the structure of the gate is suitable for automation.
- Check that the weight of the gate is within the maximum limit of 3500 Kg and 30 m in length.
- Make sure that there are no points of excessive friction in the opening or closing travel of the gate
- Make sure there is no danger of the gate derailing or exiting from its guides.
- Make sure that the mechanical stops are sturdy enough, and that there is no risk of deformation even when the leaf hits the mechanical stop violently
- Make sure that the gate is well balanced. It must not move by itself when it is placed in any position.
- Make sure there is no risk of flooding in the area in which the gear motor is fixed. Mount the gear motor raised from the ground if necessary
- Make sure that the installation area enables the release of the gear motor and that it is safe and easy to release.
- Make sure that the mounting positions of the various devices are protected from impacts and that the mounting surfaces are sufficiently sturdy
- Never immerse components in water or other liquids
- Keep TUB3500 away from heat sources and naked flames; in potentially explosive atmospheres, especially acidic or saline; Situations such as these could damage TUB3500 and cause either malfunctions or dangerous situations.
- If there is an access door in the leaf, or within the movement range of the gate, make sure that it does not obstruct normal travel, if necessary mount a suitable interblock system.
- Connect the control unit to a power supply line equipped with a safety earthing system
- The power supply line must be protected by suitable magneto-thermal and differential devices.

3.2) Installation of the gear motor

If a base for the gear motor already exists, fixing must be performed directly to the surface by means of expansion bolts.

If this is not so, it is necessary to:

1. Dig an adequately large foundation hole.
2. Prepare one or more conduits for the electrical cables as shown in Figure 5
3. Assemble the four clamps on the foundation plate setting one nut underneath and one on top of the plate as in fig. 3. so that the threaded section protrudes out of the plate as much as possible.
4. Pour the concrete and, before it starts to harden, set the foundation plate checking that it is parallel to the leaf and perfectly level as shown in Fig. 5. Wait for the concrete to harden completely
5. Remove the body from the gear motor following the procedure shown in Fig.7 in reverse order.
6. Place the gear motor on top of the foundation plate and make sure it is perfectly parallel to the leaf, then secure it by tightening the 4 nuts with washers to the respective clamps as shown in Fig. 6.
7. Release the pinion as shown in the "Release and manual movement" paragraph in the Chapter "Instructions and Warnings for users of the TUB3500 gear motor"
8. Open the leaf up completely and place the first piece of the rack on the pinion and check that the beginning of the rack corresponds to the beginning of the leaf. Make sure that there is at least 2÷3 mm of play between the rack and the pinion, then fasten the rack to the leaf using suitable means.
9. Slide the leaf, using the pinion as a reference point for the fastening the other elements of the rack
10. Cut away any excess of the rack
11. Open and close the gate several times and make sure that the rack is aligned with the pinion with a maximum tolerance of 10-15 mm. Moreover, check that the play of 2-3 mm between the pinion and the rack has been respected along the entire length.
12. Fix the two "Opening" and "Closing" limit switch brackets with the relative dowels to the outer sides of the rack as shown in Figure 4. Considering that the leaf will slide for a further 2÷3 cm after the limit switches have activated, the brackets should be positioned at a sufficient distance from the mechanical stops.
13. Perform the operation described in point 7 in reverse and block the pinion.
14. Secure the body to the TUB3500 as shown in Fig. 7 and ensure that the limit switch lever positioned above the pinion moves freely.
15. Close the gear motor door and make sure that the safety microswitch positioned to the right of the electric motor is activated.

⚠ In order to prevent the weight of the leaf from affecting the gear motor, it is important that there is a play of 2÷3 mm between the rack and the pinion.

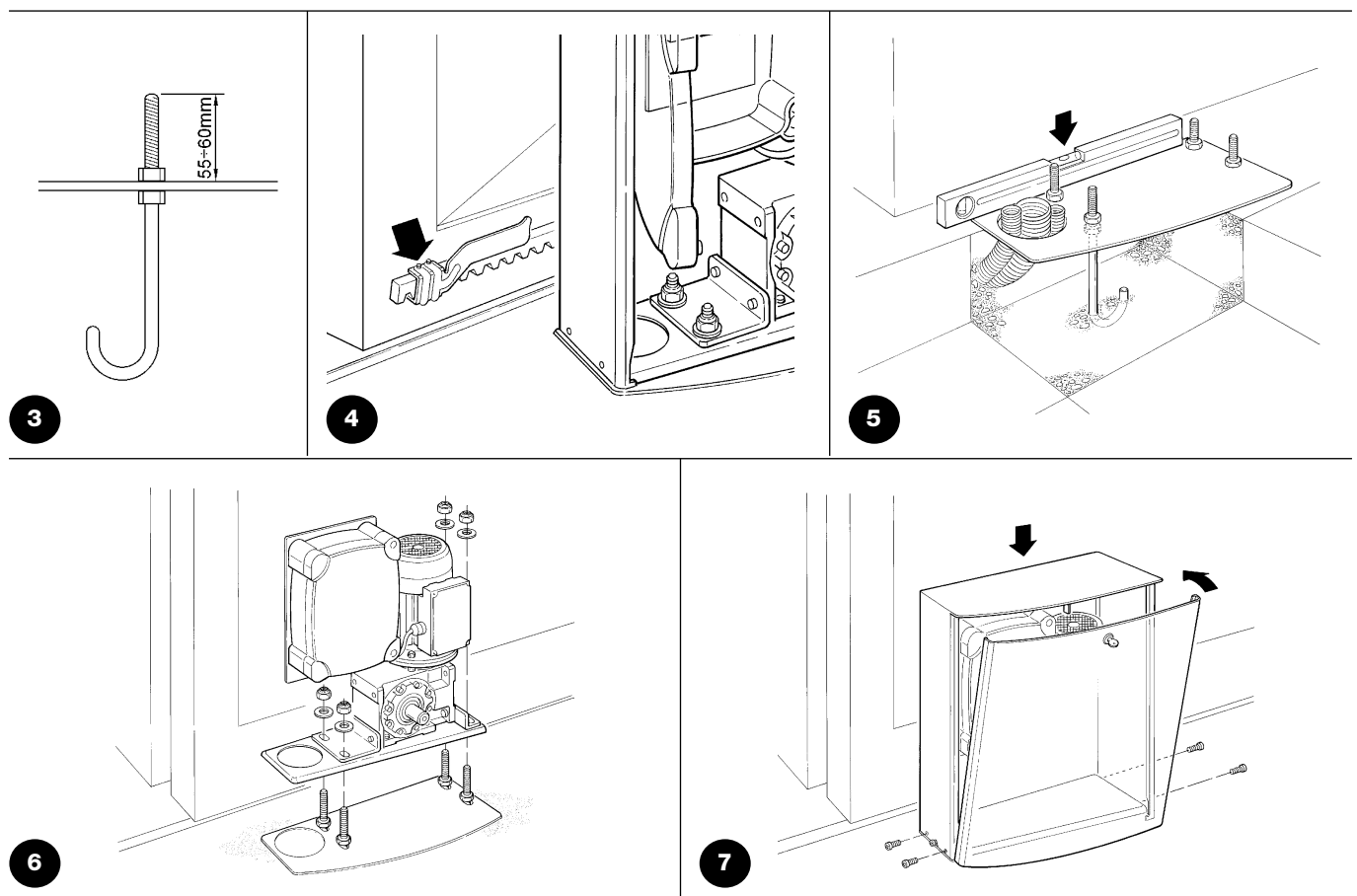

3.3) Installation of the various devices to the control unit.

Perform the installation of all foreseen devices following the respective instructions. Check which devices can be connected to the TUB3500 from the "MindyA500" manual.

3.4) Electrical connections

⚠ The electrical connections must be performed by skilled and qualified personnel in strict observance of current legislation, standards and regulations with the system disconnected from electricity supply.

1. The two yellow plastic screws must be removed in order to open the control unit door and access the electronic control board of the TUB3500.

2. Cut the cable slop, positioned beneath the control unit, to the correct size so that all the electrical cables can pass through.
3. Secure the cables with a couple of cable clips.
4. To perform the electrical connections, carefully follow the control unit instructions in the "mindyA500" manual.

4) Operating control

Position the gate approximately halfway along its total travel so that it can be easily opened or closed before performing the control and starting the automation.

4.1) Power supply connection

⚠ The connection of TUB3500 to the mains must be made by qualified and experienced personnel in possession of the necessary requisites and in full respect of the laws, provisions and standards currently in force.

• As soon as power is supplied to the TUB3500 by means of the magneto-thermal switch on the power unit, check that the OK Led in the centre of the unit starts to flash and that the Photo input led is on.

- Now push the microswitch lever, which is positioned to the right of the electric motor, and check that the ALT led and the FCA and FCC limit-switch leds light.
- If this does not happen, turn the power off straight away from the control unit and check carefully the electrical connections.
- Further troubleshooting information can be found in the "mindyA500" control unit manual.

4.2) Direction control

For motors with three-phase power supply, the direction in which the motor moves depends on the connection of the 3 power supply phases, therefore it is impossible to see before hand if the motor turns in the desired direction and if the limit switches intervene in the required direction.

It is necessary to perform the controls following the procedure below to set-up the movement direction.

a. Motor direction control:

Position the gate half open and give an impulse command on the Open input of the A500 control unit (terminal 20) and check if the gate actually performs an opening movement. If the direction is correct pass to the next point, otherwise turn off the power to the

control unit straight away and invert the cables on terminals 3 and 4 of the A500 terminal block, then check the direction of the motor once again.

b. Limit-switch intervention control:

During the opening manoeuvre of the motor and before the gate is completely open, simulate the intervention of the limit-switch in the required direction and check that the manoeuvre stops, if this does not happen, turn off the power to the control unit and invert the connections of terminals 10 and 12 of the A500 terminal block, then perform the control of the limit-switch intervention once again.

4.3 Gate movement control

Once the limit-switch brackets have been secured (Fig. 4) in the rack, perform a few manoeuvres to make sure that the gate is moving correctly.

1. Control an opening manoeuvre:

- a. Make sure the gate opens with an even speed;
- b. Make sure that the limit-switch bracket (Fig.4) activate the micro-switch, stopping the leaf with a maximum movement of 2-3 cm (be careful because the time required for the leaf to stop may increase when hot).
- c. When the gate has stopped moving, check that it finished 4-5cm away from the end stop.

2. Control a closing movement: as in point 1 .

3. If the stopping distance of the gate is greater than 2-3 cm, adjust the mechanical brake as shown in paragraph "5.1 Testing".

4. Perform a number of opening and closing manoeuvres to highlight possible fitting and adjustment errors or other errors such as points of greater friction.

5. Make sure that the TUB3500 gear motor, rack and limit-switch brackets are well secured, stable and adequately resistant especially during the sharp starting and stopping movements of the gate.

5) Testing and commissioning

These are the most important stages in the automation system installation procedure in order to ensure the maximum safety levels. Testing can also be adopted as a method of periodically checking that all the various devices in the system are functioning correctly.

⚠ Testing of the entire system must be performed by qualified and experienced personnel who must establish which tests to conduct on the basis of the risks involved, and verify the compliance of the system with applicable regulations, legislation and standards, in particular with all the provisions of EN standard 12445 which establishes the test methods for automation systems for gates

5.1) Testing

Each component of the system, e.g. safety edges, photocells, emergency stop, etc. requires a specific testing phase. We therefore recommend observing the procedures shown in the relative instruction manuals.

To test TUB3500 proceed as follows

1. Ensure that the instructions outlined in this manual and in particular in chapter 1 "Warnings" have been observed in full;
2. Using the control or stop devices (key-operated selector switch, control keys or radio transmitter) test the opening, closing and stopping of the gate and make sure that the leaves move in the intended direction
3. Check the proper operation of all the safety devices, one by one (photocells, sensitive edges, emergency stop, etc.).
4. If the dangerous situations caused by the movement of the leaf have been safeguarded by limiting the force of impact, the user must measure the impact force according to EN Standard 12445.
5. Check that the stopping distance of the gate is 2-3 cm, otherwise adjust the mechanical brake as follows (figure 8):
 - a. Give the nut on the motor shaft a half turn in a clockwise direction;
 - b. If the half turn isn't enough, turn the nut a little bit more;
 - c. Be careful not to over tighten the nut because it could completely block the electric motor.

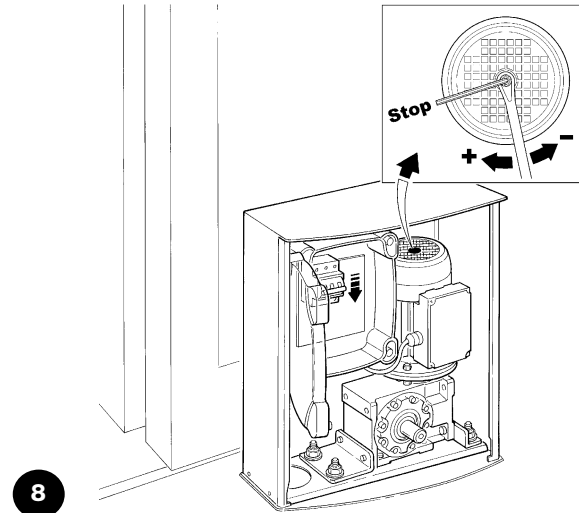

8

⚠ Before adjusting the mechanical brake, the power supply must be turned off placing the magneto-thermal switch on the control unit in the "OFF" position.

5.2) Commissioning

Commissioning can take place only after all the testing phases of the TUB3500 and the other devices have been terminated successfully. It is not permissible to execute partial commissioning or to enable use of the system in makeshift conditions.

1. Prepare and store for at least 10 years the technical documentation for the automation, which must include at least: assembly drawing of the automation, wiring diagram, analysis of hazards and solutions adopted, manufacturer's declaration of conformity of all the devices installed (use the annexed CE declaration of conformity for TUB3500); copy of the instruction manual and maintenance schedule of the automation.
2. Post a label on the gate providing at least the following data: type of automation, name and address of manufacturer (person responsible for "commissioning"), serial number, year of manufacture and "CE" marking.
3. Post a permanent label or sign near the gate detailing the operations for the release and manual manoeuvre.
4. Prepare the declaration of conformity of the automation system and deliver it to the owner
5. Prepare the "Installation instructions and warnings" of the automation system and deliver it to the owner
6. Prepare the maintenance schedule of the automation system and deliver it to the owner; it must provide all directions regarding the maintenance of the single automation devices.
7. Before commissioning the automation system inform the owner in writing regarding dangers and hazards that are still existing (e.g. in the "Installation instructions and warnings").

6) Maintenance and disposal

This chapter provides information about how to draw-up a maintenance schedule, and the disposal of the TUB3500.

6.1) Maintenance

The automation must be subjected to regular maintenance, in order to guarantee it lasts and to maintain its level of safety.

⚠ The maintenance operations must be performed in strict compliance with the safety directions provided in this manual and according to the applicable legislation and standards.

If other devices are present, follow the directions provided in the corresponding maintenance schedule.

1. TUB3500 requires scheduled maintenance work every 6 months or 10,000 manoeuvres (max.) after the previous maintenance:
2. Disconnect all power supplies

3. Check for any deterioration of the components which form the automation, paying particular attention to erosion or oxidation of the structural parts. Replace any parts which are below the required standard.
4. Check the wear and tear on the moving parts: pinion, rack and the leaf components; if necessary replace them.
5. Connect the electric power sources up again, and carry out all the test and checks foreseen in Paragraph "5.1 Testing".

6.2) Disposal

TUB3500 is constructed of various types of materials, some of which can be recycled: steel, aluminium, plastic, electric cables; while others must be disposed of.

⚠ Some electronic components may contain polluting substances; do not pollute the environment. Enquire about the recycling or disposal systems available in compliance with regulations locally in force.

1. Disconnect the power supply of the automation system
2. Disassemble all the devices and accessories, following in reverse order the procedures described in chapter 3 "Installation".

3. Wherever possible, separate any parts which can or must be recycled or disposed of in different ways, e.g. metal parts must be disposed of separately from plastic ones, as must the electronic cards etc.
4. Sort the various materials and consign them to local licensed firms for recovery and disposal.

7) Technical characteristics

Nice S.p.a., in order to improve its products, reserves the right to modify their technical characteristics at any time without prior notice. In any case, the manufacturer guarantees their functionality and fitness for the intended purposes. All the technical characteristics refer to a room temperature of 20°C (±5°C).

Technical characteristics: TUB3500

Type	Electromechanical self-braking gear motor for the automatic movement of sliding gates for industrial use, complete with electronic control unit
Pinion	Z= 18; Module =6; Pitch =18.8; Pitch diameter =108mm
Peak thrust	418Nm; corresponds to the ability to start a leaf moving with a maximum static friction of 7740N
Nominal torque	190Nm; corresponds to the ability to keep a leaf with a dynamic friction max. 3520N moving.
Nominal torque speed	0.167m/s (10m/min)
Maximum frequency of operating cycles	200 cycles/day
Maximum continuous operating time	30 minutes (the control unit foresees a maximum operation time of 120 seconds which can be modified to 210 seconds).
Operating limits	TUB3500 is generally capable of automating gates up to 3500 Kg in weight and 30 m in length.
Power supply	Three-phase 400V ac +/-10%; 50Hz.
Max. absorbed power	550 W
Insulation class	1 (a safety earthing system is required)
Operating temperature	-20°C ÷ 50°C
Use in particularly acidic or saline atmospheres or potentially explosive	No
Protection level	IP 44
Dimension and weight	580X480X240; 60Kg

Other technical characteristics are indicated in the A500 control unit instructions

Instructions and warnings for users of the TUB3500 gear motor

Congratulations on choosing a Nice product for your automation system!

Nice S.p.A. produces components for automating gates, doors, shutters and awnings: gear motors, control units, radio control units, flashing lights, photocells and accessories.

Nice only uses first rate materials and production processes and constantly develops innovative technical, aesthetic and ergonomic solutions in order to make its products as simple to use as possible: your fitter will certainly have chosen the most suitable article for your requirements from the large range of Nice products. Nice however, is not the producer of your automated system as this is the result of a process of analysis, evaluation, choice of materials and installation performed by your fitter.

Each automated system is unique and only your fitter has the experience and professionalism required to create a system that is tailor-made to your requirements, featuring long-term safety and reliability, and, above all, professionally installed and compliant with current regulations.

An automated system is handy to have as well as being a valid security system. Just a few, simple operations are required to ensure it lasts for years.

Even if your automated system satisfies regulatory safety levels, this does not eliminate "residue risks", that is, the possibility of dangerous situations being generated, usually due to irresponsible or incorrect use. For this reason we would like to give you some suggestions on how to avoid these risks:

- **Before using your automated system** for the first time, ask your fitter to explain how residue risks can arise and spend a few minutes reading the **instructions and warnings for the user** handbook that the fitter will have given you. Keep this manual for future use and, if you should ever sell your automated system, hand it over to the new owner.

- **Your automated system is a machine which carries out your commands to the letter;** irresponsible or incorrect use may cause it to become dangerous: do not move the automated system if animals or objects are in its working radius.

- **Children:** an automated system ensures a high level of safety as it always offers reliable and safe operation and its detection systems stop it from moving in the presence of people or objects. However, children should not be allowed to play near it. Do not let them accidentally use the system by leaving the remote control unit within their reach: **it is not a toy!**

- **Faults.** If you notice any abnormal behaviour, disconnect the system from the electricity supply immediately and perform the manual release operation. Do not attempt to make repairs yourself but call in your fitter: in the meantime the system can work as a non-automated gate once the gear motor has been released as described further on.

- **Maintenance.** Just like all machines, your automated system requires periodic maintenance to ensure it works as long as possible and in total safety. Agree on a routine maintenance plan with your fitter; Nice recommends a visit once every six months for normal residential use but this period can vary depending on how often the system is used. All controls, maintenance work or repairs may only be carried out by qualified personnel.

- Do not modify the system or its programming and adjustment parameters even if you think you can do it: your fitter is responsible for this.

- Final testing, routine maintenance and any repairs must be documented by the fitter and such documents kept by the owner of the system.

- **Disposal.** At the end of the life of the automatic system, make sure that it is demolished by qualified personnel and that the materials are recycled or disposed of according to local regulations.

- **In case of breakage** or during a power failure. While waiting for your fitter to call (or power to come on again if the system does not have buffer batteries), the system can be used just like any other manual opening system. To do this, perform the manual release operation: this can be done by the user and Nice has made it as easy as possible, without the need for tools or physical effort.

Manual movement and release: before carrying out this operation **please note** that release can only occur when the leaf is stationary.

1. Open the TUB3500 door with the supplied key figure 9.
2. Take the hexagonal key and insert it into the shaft figure 10.
3. Unscrew the screw inside the shaft **completely** as shown in figure 11.
4. Remove the hexagonal key and close the TUB3500 door.
5. Manually manoeuvre the leaf as shown in figure 12.

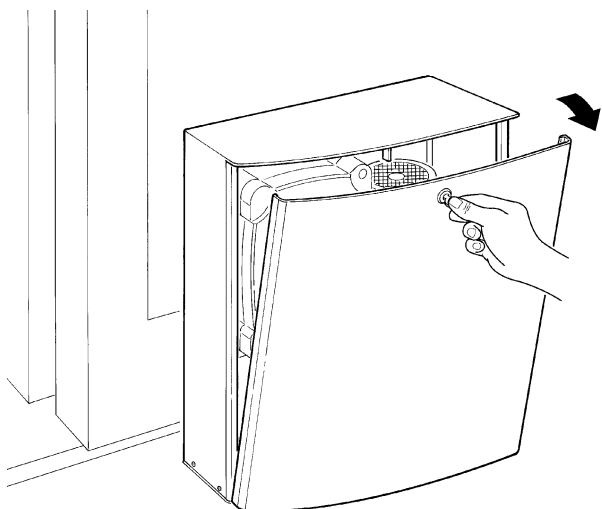

9

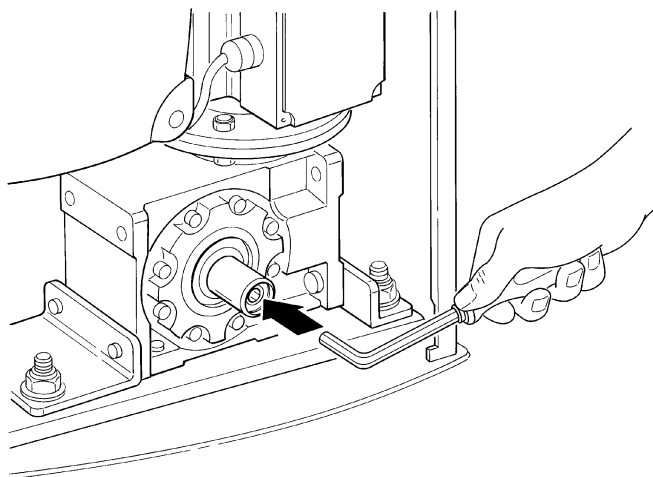

10

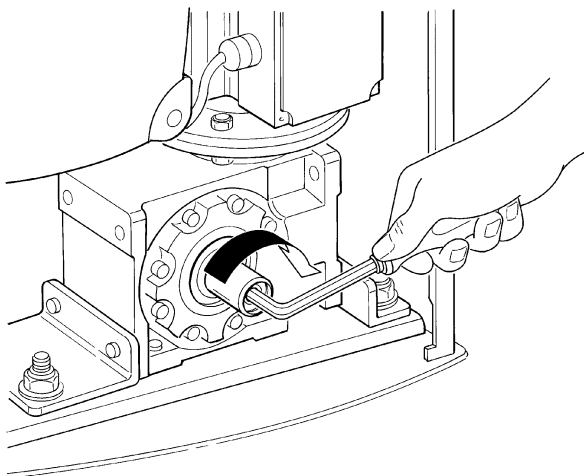

11

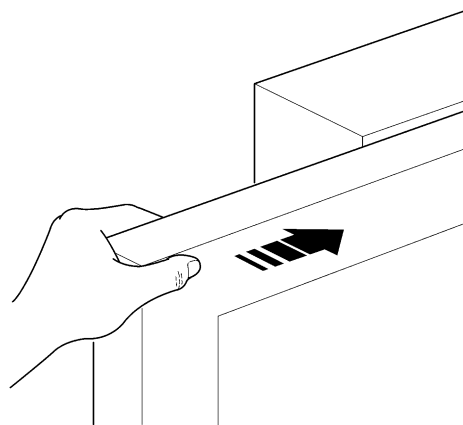

12

To block: follow the same operations in reverse order

If a fault occurs the automation must be repaired as soon as possible.

Are you satisfied? If you wish to add a new automated system to your house, contact your fitter and we at Nice will provide the advice of a specialist, the most developed products on the market, leading-edge operativeness and maximum compatibility.

Thank you for reading these suggestions and we trust you are fully satisfied with your new system: please contact your fitter for all your current or future requirements.