

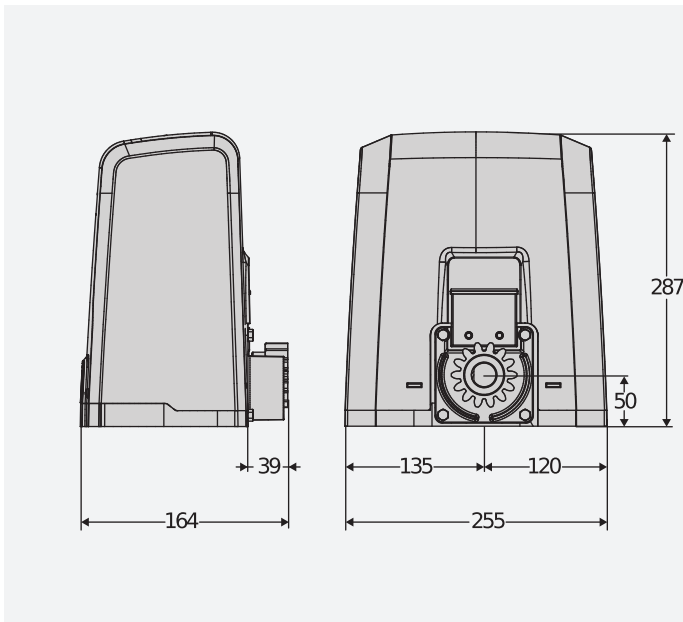

Range of operators for sliding gates weighing up to 600 Kg.
 Maximum leaf speed up to 16 m/min.
 Newly designed magnetic limit switch for quicker installation; precise and perfectly integrated with architecture of site.
 Residential use.
 Control unit designed for use with the Blue Entry system.

DIMENSION (MM)



TECHNICAL FEATURES

	DEIMOS ULTRA BT A400	DEIMOS ULTRA BT A400 V	DEIMOS ULTRA BT A600	DEIMOS ULTRA BT A600 V
Control unit	MERAK SL1		MERAK SL2	
Board power supply	230 V	230 V	230 V	230 V
Supply voltage AC	24 V	24 V	24 V	24 V
Power input	50 W	50 W	70 W	70 W
Max. door/gate weight	400 kg	300 kg	600 kg	360 kg
Gate speed	12 m/min	16 m/min	12 m/min	16 m/min
Type of limit switch	Magnetic	Magnetic	Magnetic	Magnetic
Pinion module	4	4	4	4
Slowdown	Yes	Yes	Yes	Yes
Locking	Mechanical	Mechanical	Mechanical	Mechanical
Release	Lever-operated with personal key	Lever-operated with personal key	Lever-operated with personal key	Lever-operated with personal key
Impact reaction	D-Track	D-Track	D-Track	D-Track
Frequency of use	intensive	intensive	intensive	intensive
Protection rating	IP44			
Environmental conditions	-20 ÷ 55 °C			

		Description	
P925221 00002	DEIMOS ULTRA BT A400	Operator 24 V for sliding gates up to 400 kg in weight. Leaf speed 12 m/min. U-Link and Magnetic limit switch.	U-Link
P925221 00003	DEIMOS ULTRA BT A400 V	Operator 24 V for sliding gates up to 300 kg in weight. Leaf speed 16 m/min. U-Link and Magnetic limit switch.	U-Link
P925223 00002	DEIMOS ULTRA BT A600	Operator 24 V for sliding gates up to 600 kg in weight. Leaf speed 12 m/min. U-Link and Magnetic limit switch.	U-Link
P925223 00003	DEIMOS ULTRA BT A600 V	Operator 24 V for sliding gates up to 360 kg in weight. Leaf speed 16 m/min. U-Link and Magnetic limit switch.	U-Link
R925285 00002	DEIMOS ULTRA BT KIT A400 AUSTRALIA	Complete kit 24 V for sliding gates weighing up to 400 kg. Leaf speed 12 m/min. U-Link and Magnetic limit switch.	
R925013 70001	DEIMOS ULTRA BT KIT A600 FAST	Complete kit 24 V for sliding gates weighing up to 360 kg. Leaf speed 16 m/min. U-Link and Magnetic limit switch.	

MERAK: Incorporated control unit for one 24V operator for sliding gates.

MERAK - Built-In



- Incorporated control unit for one 24V operator for sliding gates
- Board power supply: 230V single-phase
- Operator power supply: 24V 80W
- Main characteristics: removable terminal boards with new colour standard, simplified programming with scenario display, integrated two-channel receiver, D-Track based antisquashing system and slowdown during opening or closing
- Main functions: automatic closing, quick closing, pedestrian passage, people-present operation, maintenance warnings
- Compatibility: HQSC-D, QSC-D MA

RECOMMENDED ACCESSORIES

	D221073 - CP		N999320 - CVZ-S
	plastic rack, 4-module, cross-section 22 x 22 mm, length 1 m, screw-fitted into slots. Max. load capacity 600 kg.		steel rack, 4-module, cross-section 30 x 8 mm, length 1 m, screw-fitted on supports. Max. load capacity 800 kg.
	N999151 - SFD		P125035 - SL BAT2
	Base plate for DEIMOS series (supplied with operator).		Emergency battery kit for Deimos BT A, Ares BT A, Deimos Ultra BT A, Ares Ultra BT A.

