



Motorisation pour portails battants

FR - Instructions et avertissements pour l'installation et l'utilisation

EN - Instructions and warnings for installation and use

IT - Istruzioni ed avvertenze per l'installazione e l'uso

PL - Instrukcje i ostrzeżenia do instalacji i użytkowania

1

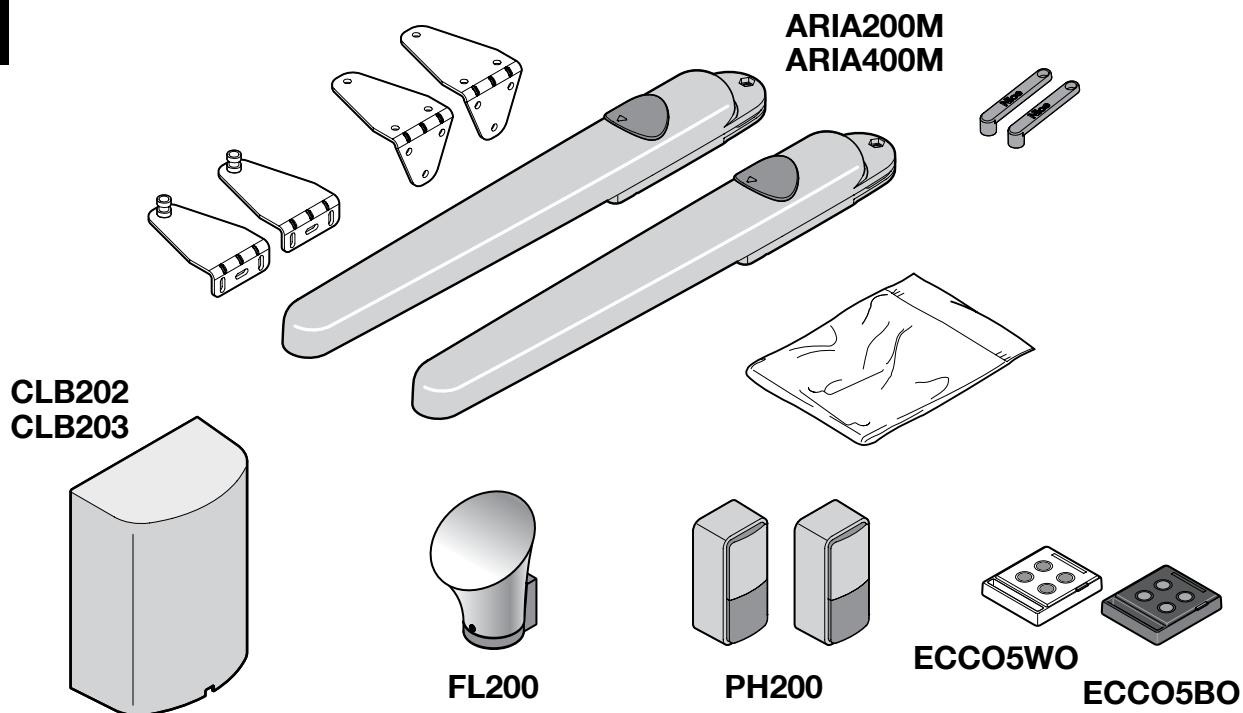

KIT ARIA200	
ARIA200M	n° 2 ARIA200M
CLB202	n° 1 CLB202
FL200	n° 1 FL200
PH200	un paio PH200
ECCO5WO	n° 1 ECCO5WO
ECCO5BO	n° 1 ECCO5BO
KIT ARIA200START	
ARIA200M	n° 1 ARIA200M
CLB202	n° 1 CLB202
ECCO5BO	n° 1 ECCO5BO
KIT ARIA400	
ARIA400M	n° 2 ARIA400M
CLB203	n° 1 CLB203
FL200	n° 1 FL200
PH200	un paio PH200
ECCO5WO	n° 1 ECCO5WO
ECCO5BO	n° 1 ECCO5BO

• FR - Les accessoires en option non inclus dans l'emballage sont consultables sur le site : www.niceforyou.com • EN - The optional accessories not included in the package can be viewed on the following website: www.niceforyou.com • IT - Gli accessori opzionali non presenti nella confezione sono consultabili sul sito: www.niceforyou.com • PL - Opcjonalne urządzenia dodatkowe, które nie są załączone do opakowania są opisane na stronie: www.niceforyou.com

FR	Les pages suivantes décrivent seulement par le biais d'images les principales phases (divisées en étape) pour créer l'installation souhaitée : étape A = observer → étape B = installer → étape C = raccorder → étape D = premier allumage de l'installation effectué par un électricien qualifié → étape E = programmer.
EN	The pages below describe with images alone the main phases (divided into steps) to create the desired system: Step A = observe → Step B = install → Step C = connect → Step D = initial start-up of the system carried out by a qualified electrician → Step E = programme.
IT	Le pagine seguenti, descrivono solo con immagini le fasi principali (divise a step) per creare l'impianto desiderato: step A = osservare → step B = installare → step C = collegare → step D = prima accensione dell'impianto eseguito da un elettricista qualificato → step E = programmare.
PL	Na kolejnych stronach opisano, za pomocą rysunków, główne fazy (z podziałem na kroki) umożliwiające utworzenie wymaganej instalacji: krok A = obserwacja → krok B = montaż → krok C = połączenie → krok D = pierwsze uruchomienie instalacji wykonane przez wykwalifikowanego elektryka → krok E = programowanie.

step A pag. I - 2		step B pag. I - 2		step C pag. VIII - 6		step D pag. 6		step E pag. 6	
----------------------	--	----------------------	--	-------------------------	--	------------------	--	------------------	--

Step A



2

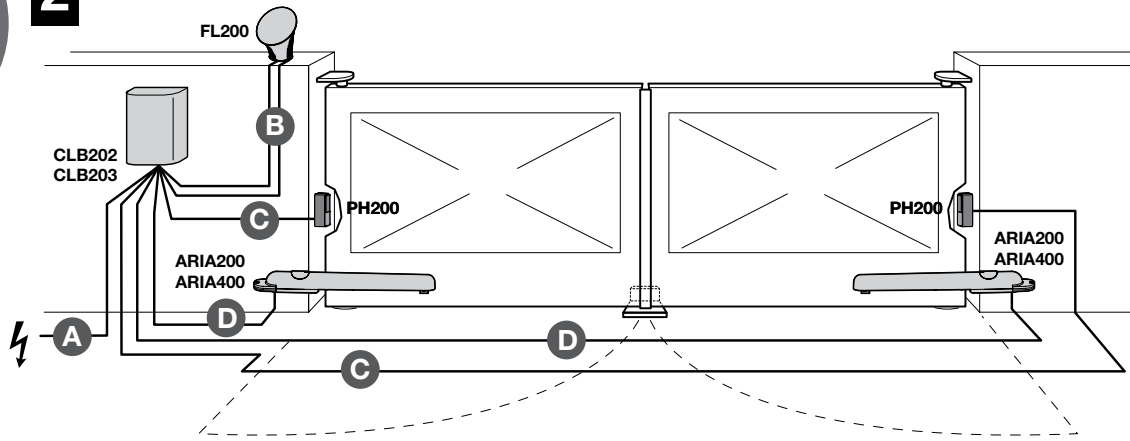

A B C D = • FR - Voir le tableau 2 (paragraphe 3.4) • EN - See Table 2 (Par. 3.4) • IT - Vedere Tabella 2 (parag. 3.4) • PL - Patrz Tabela 2 (punkt 3.4)

Step B



3

01.

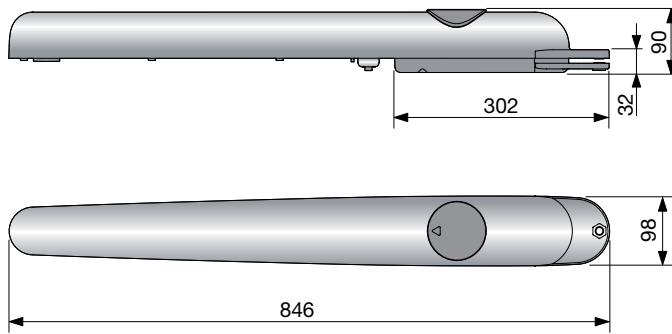

02.

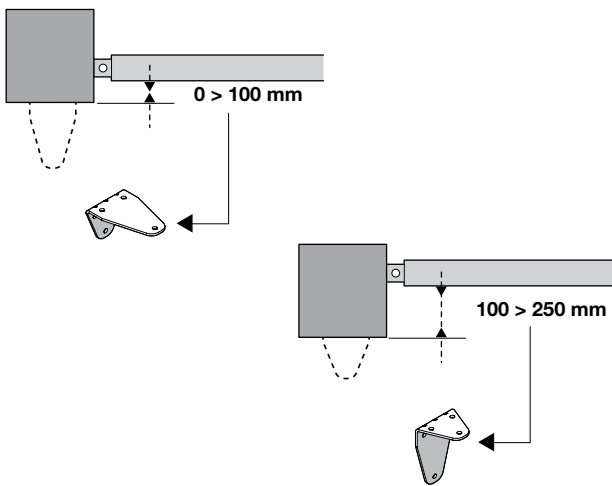

03.

• FR - Tableau 1 • EN - Table 1 • IT - Tabella 1 • PL - Tabela 1

A 160 B 240	100°	A 205 B 180	110°	A 160 B 240	95°	A 115 B 290	90°
A 180 B 220	95°	A 200 B 190	105°	A 150 B 250	95°	A 110 B 325	90°
A 190 B 200	95°	A 190 B 210	100°	A 140 B 260	95°		
A 200 B 180	95°	A 180 B 220	100°	A 130 B 270	90°		
A 210 B 160	95°	A 170 B 230	95°	A 125 B 280	90°		

04.

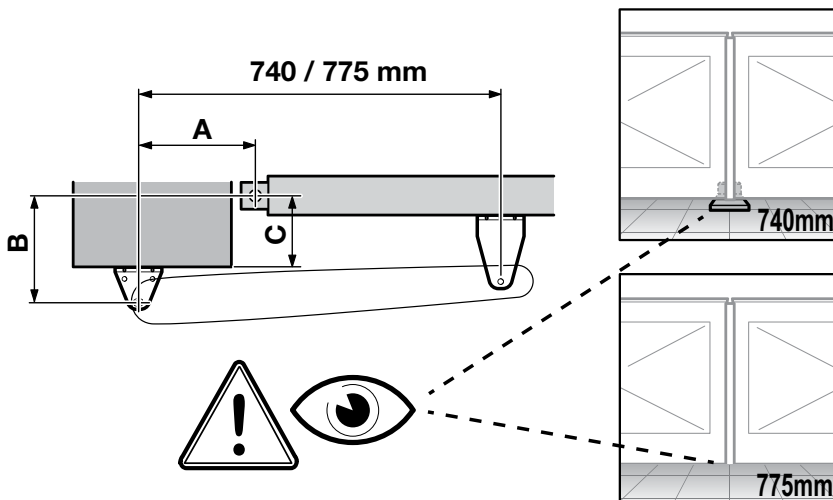

05.

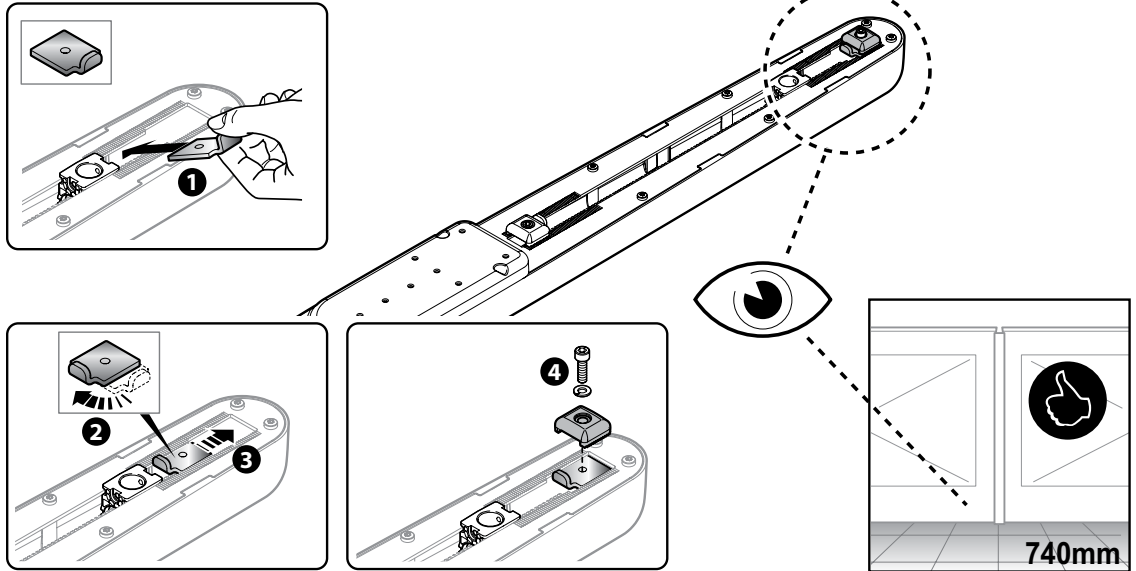

06.

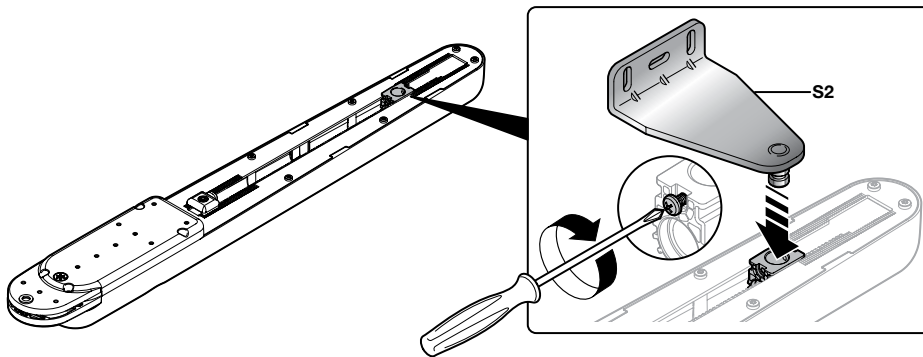

07.

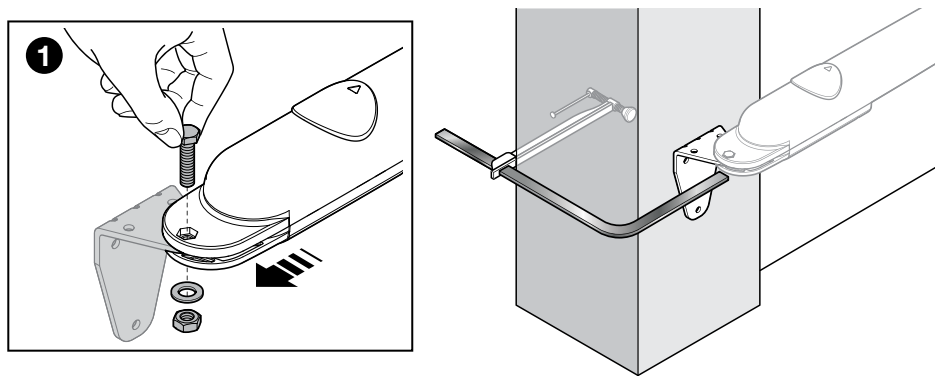

08.

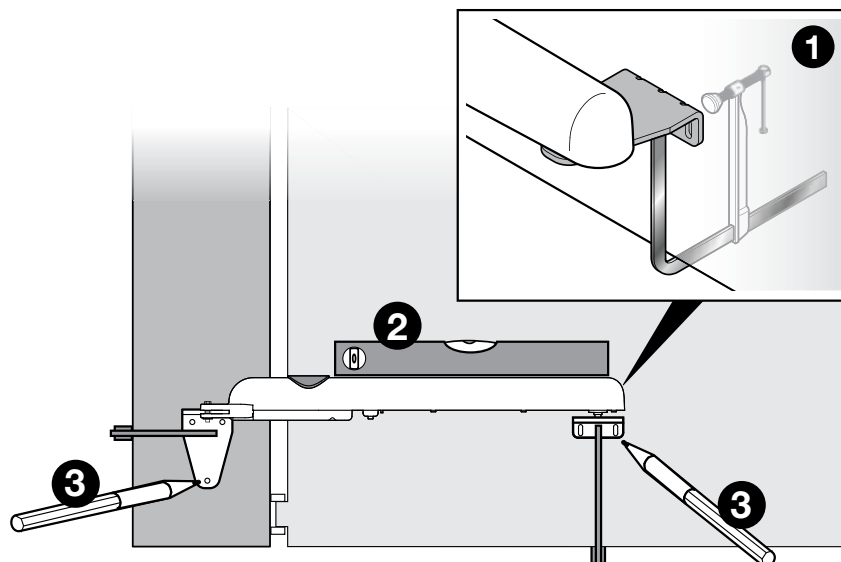

09.

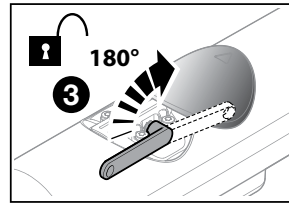
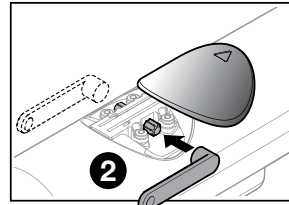
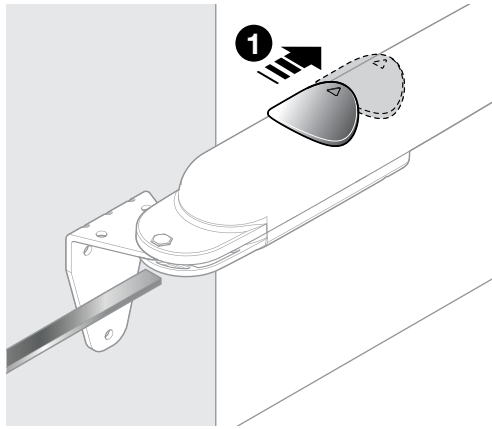

10.

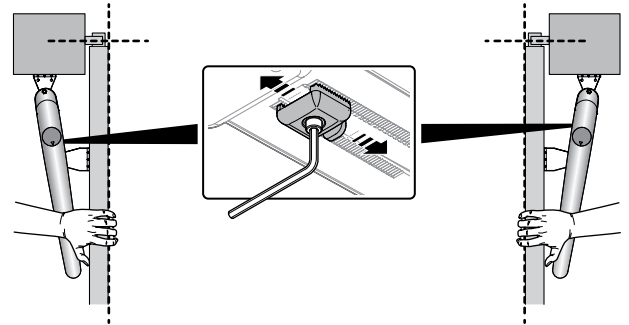
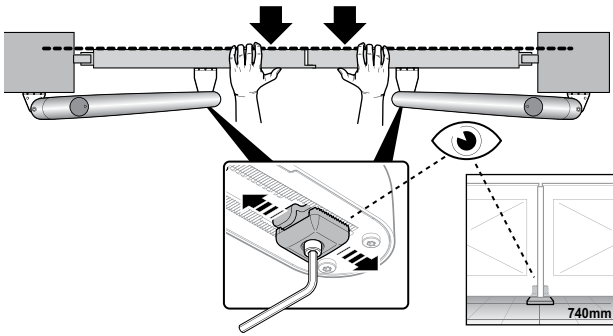

11.

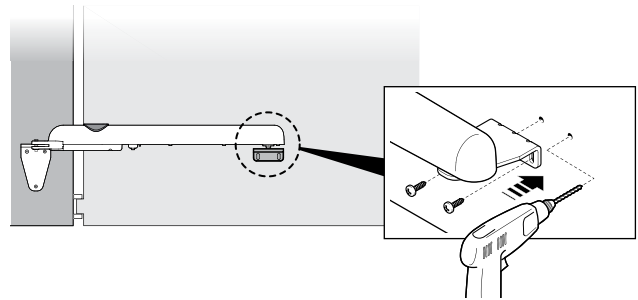
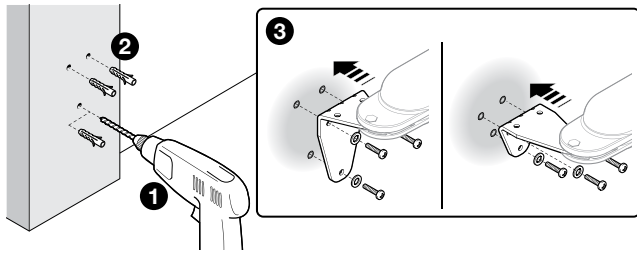

12.

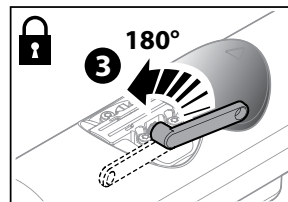
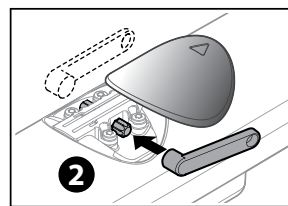
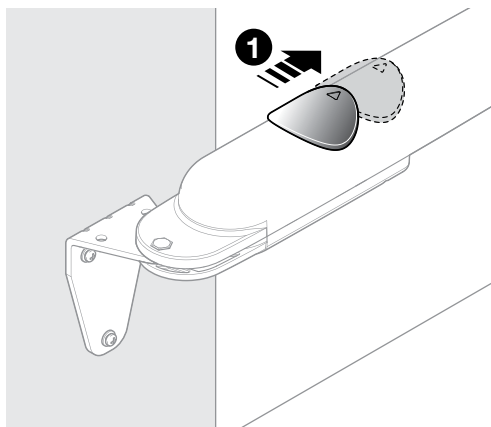

4 01.

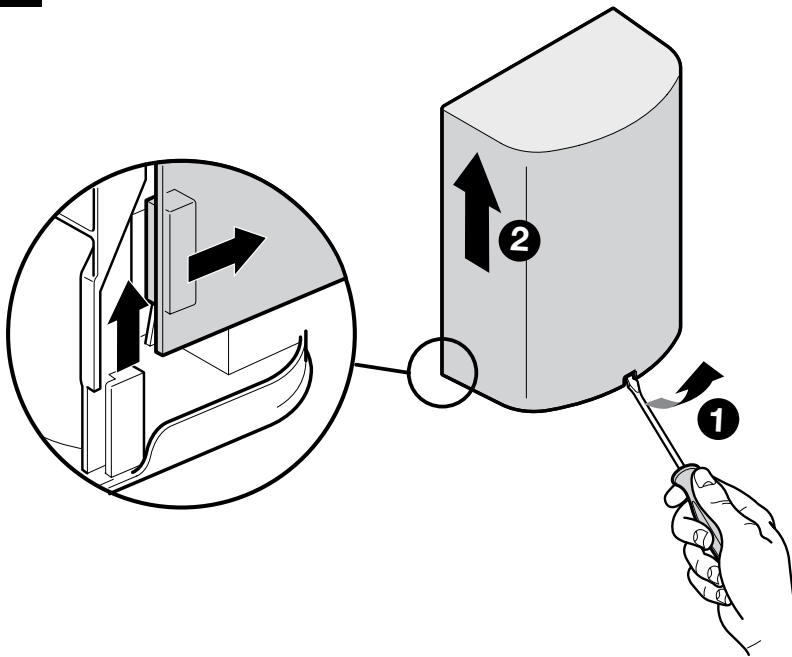

02.

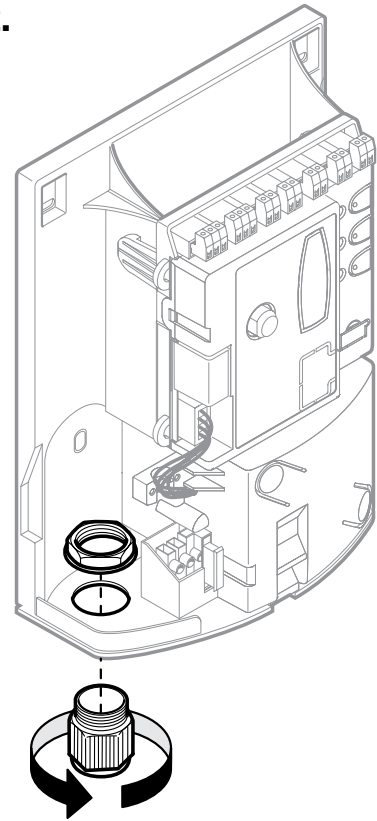

03.

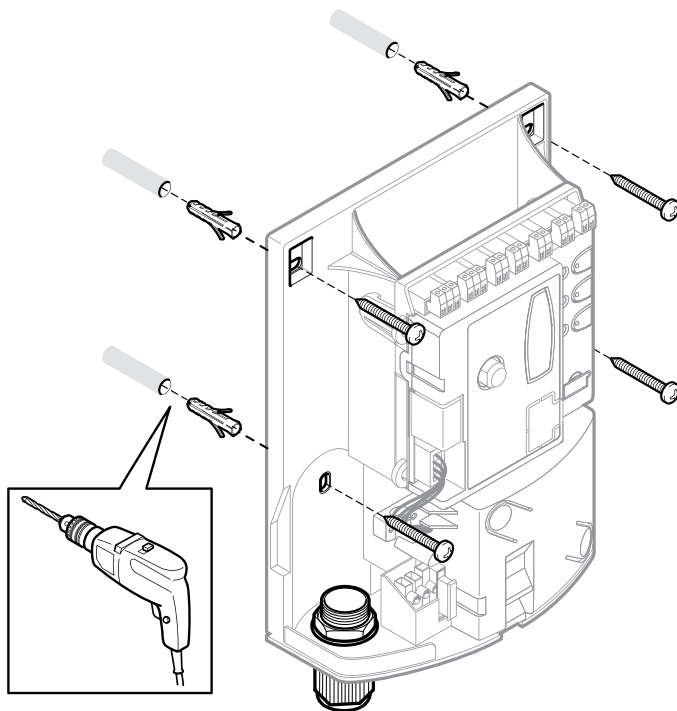

PH200

FR Installation des photocellules > fig. 5 - paragraphe 3.6

EN Installation of photocells > Fig. 5 - Paragraph 3.6

IT Installazione fotocellule > fig. 5 - paragrafo 3.6

PL Montaż fotokomórek > rys. 5 - punkt 3.6



FL200

FR Installation du clignotant > fig. 6 - paragraphe 3.7

EN Installation of photocells > Fig. 6 - Paragraph 3.7

IT Installazione lampeggiante > fig. 6 - paragrafo 3.7

PL Montaż lampy ostrzegawczej > rys. 6 - punkt 3.7

5

PH200

01.

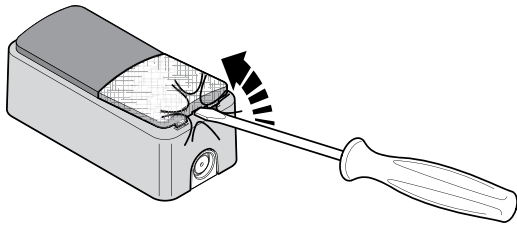

02.

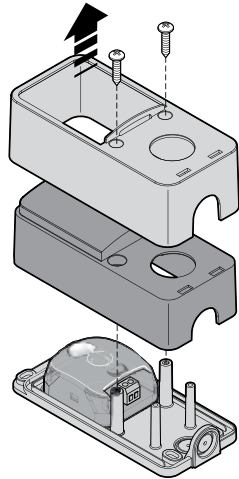

03.

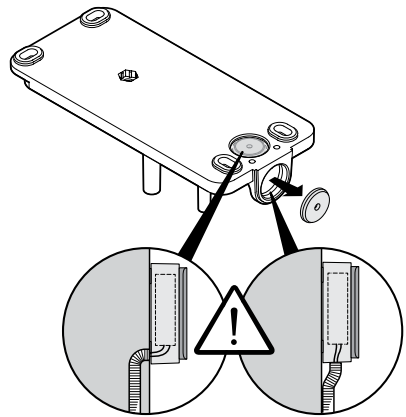

04.

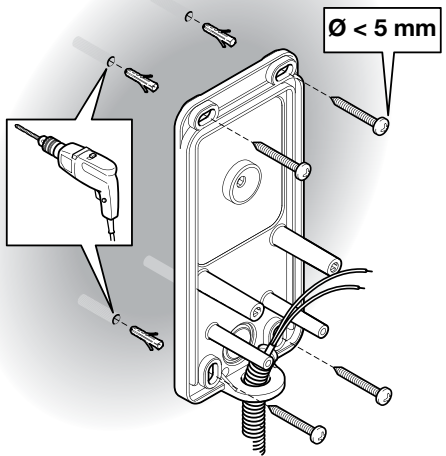

05.

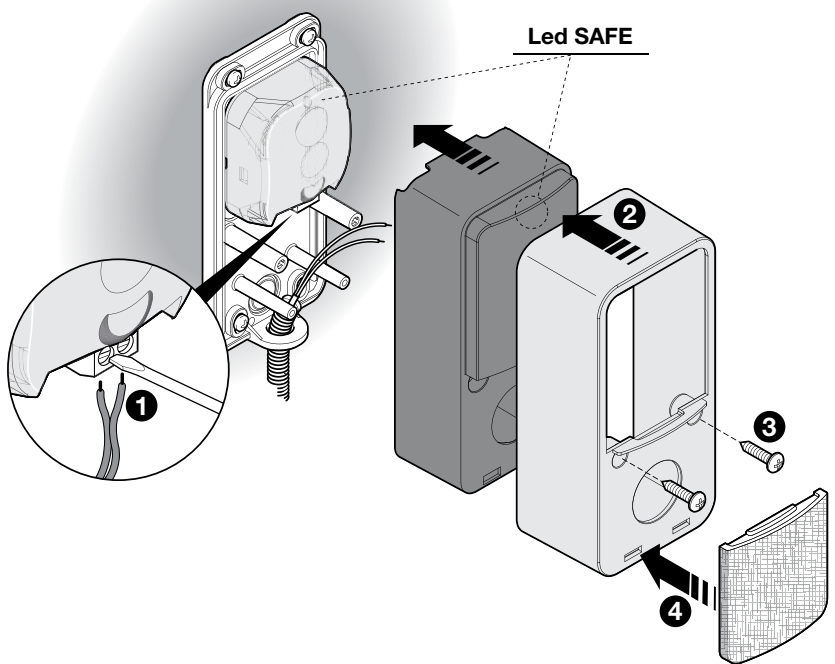

6

 FL200

01.

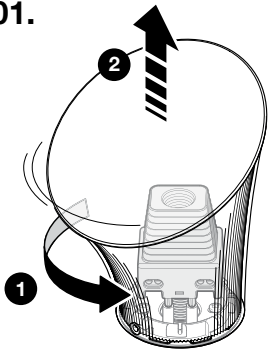

02.

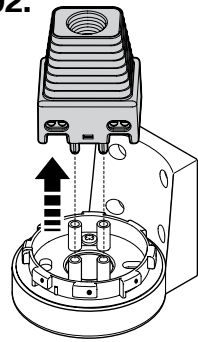

03.

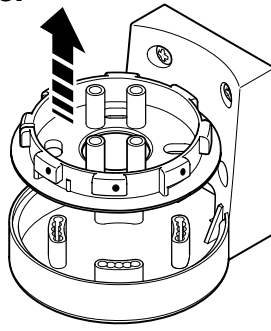

04.

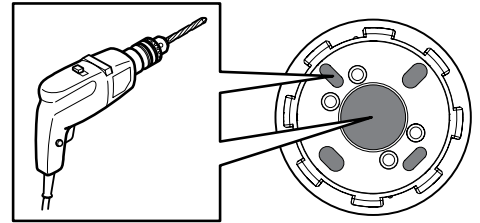

05. A

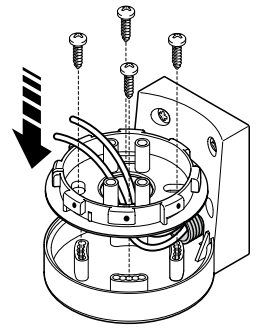
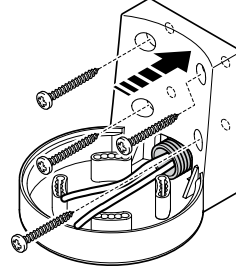
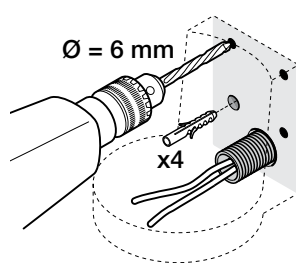
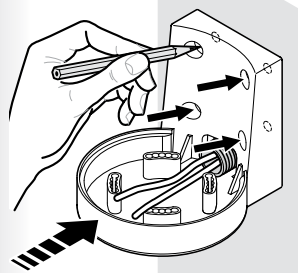
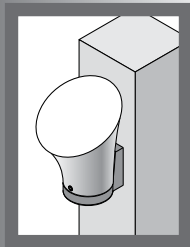

05. B

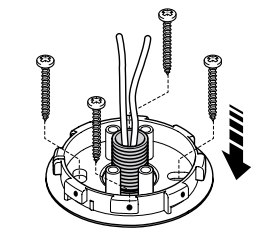
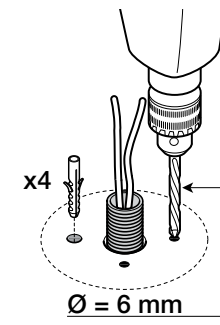
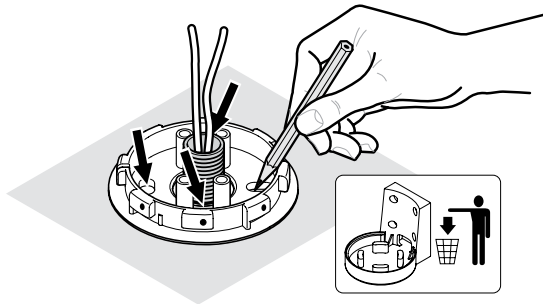
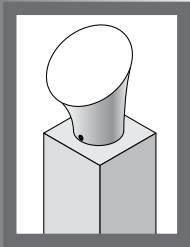

06.

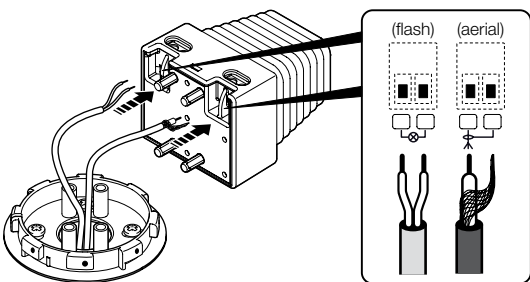

07.

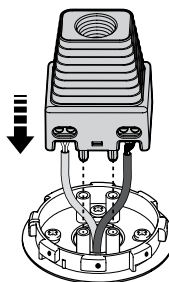

08.

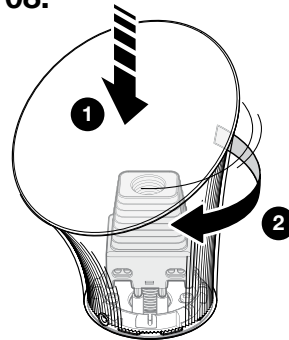

09.

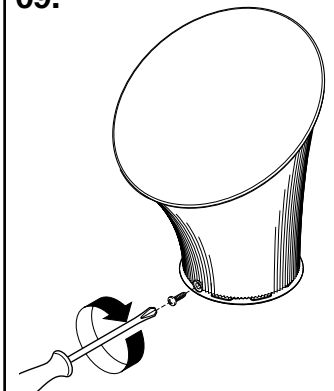

Step C



7

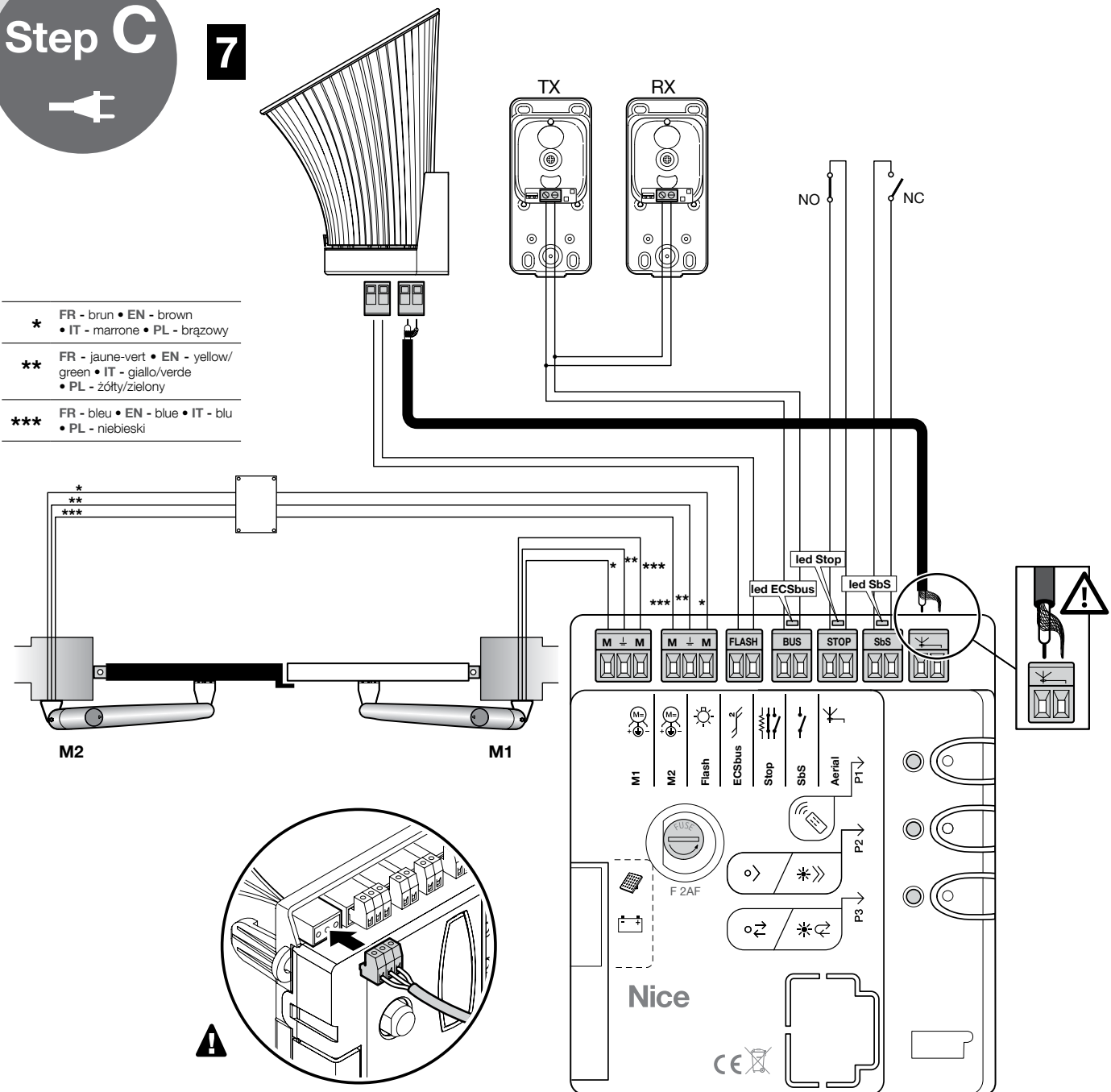

FR	Après avoir raccordé tous les composants du kit et avant de fermer le couvercle de l'opérateur (fig. 8), il est possible de procéder à la connexion de tous les autres composants requis pour l'installation (option et non inclus dans l'emballage).
EN	After having connected all the components of the kit and before closing the cover of the gearmotor (Fig. 8), it is possible to connect other components designed for the system (optional and not present in the package).
IT	Dopo aver collegato tutti i componenti del kit e prima di chiudere il coperchio del motoriduttore (fig. 8), è possibile procedere al collegamento di altri eventuali componenti previsti per l'impianto (opzionali e non presenti nella confezione).
PL	Po podłączeniu wszystkich części zestawu, przed zamknięciem pokrywki motoreduktora (rys. 8) można przystąpić do podłączenia innych części przewidzianych dla instalacji (opcjonalnych i niedołączonych do opakowania).

8

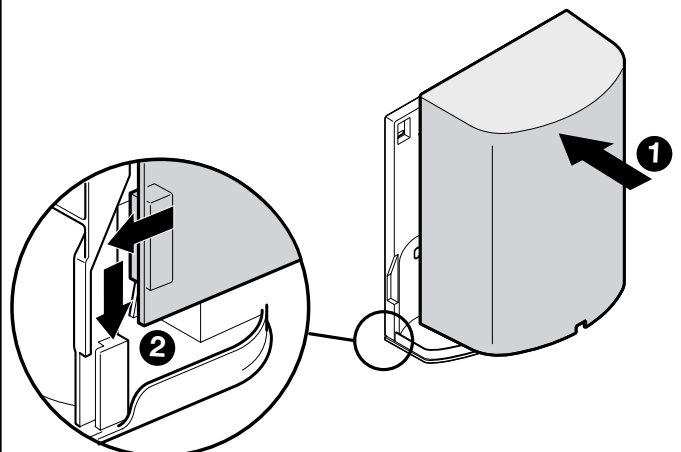

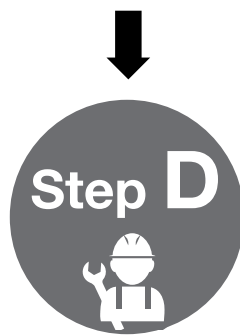

FR	Voir le chapitre 5 pour procéder au premier allumage du système. ⚠ Cette phase doit être effectuée exclusivement par un électricien qualifié.
EN	To start-up the system, see Chapter 5. ⚠ This phase must be carried exclusively by a qualified electrician.
IT	Per procedere con la prima accensione dell'impianto, vedere il capitolo 5. ⚠ Questa fase deve essere eseguita esclusivamente da un elettricista qualificato.
PL	Aby przystąpić do pierwszego uruchomienia instalacji, patrz rozdział 5. ⚠ Ta faza musi być wykonywana wyłącznie przez wykwalifikowanego elektryka.

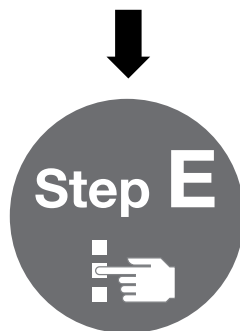

FR	Voir le chapitre 6 pour procéder à la PROGRAMMATION du système.
EN	To PROGRAMME the system, see Chapter 6.
IT	Per procedere con la PROGRAMMAZIONE dell'impianto, vedere il capitolo 6.
PL	Aby przystąpić do PROGRAMOWANIA instalacji, patrz rozdział 6.

CONTENTS

QUICK GUIDE (images only)	II-X
1 GENERAL WARNINGS: SAFETY - INSTALLATION - USE	4
2 PRODUCT DESCRIPTION AND INTENDED USE	4
3 INSTALLATION	4
3.1 VERIFYING THE SUITABILITY OF THE GATE AND ENVIRONMENT	4
3.2 VERIFYING THE PRODUCT'S APPLICATION LIMITS	4
3.3 PRODUCT TECHNICAL SPECIFICATIONS	4
3.4 PRE-INSTALLATION WORKS	5
3.5 INSTALLING THE ARIA GERMOTORS (models 400C/600C) and CLB CONTROL UNIT (models 202/203)	6
3.5.1 INSTALLING THE ARIA GERMOTORS 200M/400M	6
3.5.2 INSTALLING THE CLB202/203 CONTROL UNIT	6
3.6 INSTALLING THE PHOTOCELLS model PH200	6
3.7 INSTALLING THE FLASHING LIGHT model FL200	6
4 ELECTRICAL CONNECTIONS	7
4.1 ELECTRICAL CONNECTION TO THE CONTROL PANEL	7
4.2 POWER SUPPLY CONNECTION	7
5 PROGRAMMING	7
5.1 CONTROL UNIT KEYS	7
5.2 INITIAL CHECKS	7
5.3 MEMORISATION OF CONNECTED DEVICES	7
5.4 MEMORISATION OF GATE LEAF OPENING AND CLOSING ANGLES	8
5.5 MEMORISATION OF THE 1 ST TRANSMITTER	8
5.6 BASIC ADJUSTMENTS	9
5.6.1 Choosing the gate leaf manoeuvre speed	9
5.6.2 Choosing the operating cycle of the gate leaf manoeuvre	9
6 TESTING AND COMMISSIONING	10
6.1 TESTING	10
6.2 COMMISSIONING	10
7 MAINTENANCE	10
8 PRODUCT DISPOSAL	10
9 FURTHER INFORMATION	11
9.1 ADVANCED ADJUSTMENTS	11
9.1.1 Adjusting the parameters using the transmitter	11
9.1.1.1 Parameter adjustment procedure: Pause time - Pedestrian opening - Motor force - Step-by-Step function	11
9.1.1.2 Parameter adjustment procedure: SbS input configuration - Flash output configuration - Discharging of Motor 1 and 2 upon closing - Discharging of Motor 1 and 2 upon opening	12
9.1.2 Verifying the values set for each parameter (using the transmitter)	12
9.1.2.1 Parameter verification procedure: Pause time - Pedestrian opening - Motor force - Step-by-Step Function	12
9.1.2.2 Parameter verification procedure: Discharging of Motor 1 upon closing - Discharging of Motor 1 upon opening - Discharging of Motor 2 upon closing - Discharging of Motor 2 upon opening	12
9.2 ADDING OR REMOVING DEVICES	13
9.2.1 Memorising additional devices	13
9.3 MEMORISING ADDITIONAL TRANSMITTERS	13
9.3.1 Mode 1 memorisation procedure	13
9.3.2 Mode 2 memorisation procedure	13
9.3.3 Memorisation procedure near the control unit with two transmitters	13
9.4 DELETING THE MEMORY OF THE INDIVIDUAL TRANSMITTER FROM THE CONTROL UNIT'S MEMORY	14
9.5 COMPLETE DELETION OF THE RADIO MEMORY	14
9.6 INSTALLING THE BACK-UP BATTERY	14
9.7 INSTALLING THE SOLAR POWER SYSTEM KIT model SOLEKIT	14
9.8 DIAGNOSTICS AND DEVICE SIGNALS	14
9.8.1 Photocell signals	14
9.8.2 Flashing light signals	14
9.8.3 Control unit signals	14
9.9 SPECIFICATIONS	16
9.9.1 ECSbus system	16
9.9.2 Stop input	16
9.9.3 Product durability	16
10 TROUBLESHOOTING	17
EC Declaration of Conformity	18
11 USER GUIDE (to be delivered to the end user) (detachable insert)	A
ANNEX I (detachable insert)	B

1 GENERAL WARNINGS: SAFETY - INSTALLATION - USE (original instructions in Italian)

CAUTION

Important safety instructions. Observe all the instructions as improper installation may cause serious damage

CAUTION

Important safety instructions. It is important to comply with these instructions to ensure personal safety. Store these instructions

- Before commencing the installation, check the "Product technical specifications", in particular whether this product is suitable for automating your guided part. Should it be unsuitable, DO NOT proceed with the installation
- The product cannot be used before it has been commissioned as specified in the "Testing and commissioning" chapter

CAUTION

According to the most recent European legislation, the implementation of an automation system must comply with the harmonised standards set forth in the Machinery Directive in force, which allow for declaring the presumed conformity of the automation. On account of this, all operations regarding connection to the mains electricity, as well as product testing, commissioning and maintenance, must be performed exclusively by a qualified and skilled technician!

- Before proceeding with the product's installation, check that all materials are in good working order and are suitable for the intended applications
- The product is not intended for use by persons (including children) with reduced physical, sensory or mental capacities, nor by anyone lacking sufficient experience or familiarity with the product
- Children must not play with the appliance
- Do not allow children to play with the control devices of the product. Keep the remote controls out of reach of children

CAUTION

In order to avoid any danger from inadvertent resetting of the thermal cut-off device, this appliance must not be powered through an external switching device, such as a timer, or connected to a supply that is regularly powered or switched off by the circuit

- Provide a disconnection device (not supplied) in the plant's mains power supply, with a contact opening distance that ensures complete disconnection under the conditions envisaged by Overvoltage Category III
- Handle the product with care during installation, taking care to avoid crushing, knocks, falls or contact with liquids of any kind. Keep the product away from sources of heat and open flames. Failure to observe the above can damage the product and increase the risk of danger or malfunctions. If this should happen, stop installation immediately and contact the Customer Service
- The manufacturer assumes no liability for damage to property, items or persons resulting from non-compliance with the assembly instructions. In such cases the warranty does not cover material defects
- The weighted sound pressure level of the emission A is lower than 70 dB(A)
- Cleaning and maintenance to be carried out by the user must not be effected by unsupervised children
- Before intervening on the system (maintenance, cleaning), always disconnect the product from the mains power supply
- Check the system periodically, in particular all cables, springs and supports to detect possible imbalances, signs of wear or damage. Do not use if repairs or adjustments are necessary, because a failure with the installation or an incorrectly balanced automated system may lead to injury
- The packaging materials of the product must be disposed of in compliance with local regulations
- Keep persons away from the gate when it is moved through the control elements
- When performing a manoeuvre, keep an eye on the automated mechanism and keep all bystanders at a safe distance until the movement has been completed
- Do not operate the automation if anyone is working on it; disconnect the power supply before permitting any work to be carried out

INSTALLATION PRECAUTIONS

- Prior to installing the drive motor, check that all mechanical components are in good working order and properly balanced, and that the automation moves correctly
- If the gate being automated has a pedestrian door, the system must include a control device inhibiting the operation of the motor when the pedestrian door is open
- Make sure that the controls are kept at a safe distance from moving parts, while allowing a good view of these. Unless a selector is used, the controls should be installed at least 1.5 m from the ground and must not be accessible
- If the opening movement is controlled by a fire-prevention system, make sure that any windows larger than 200 mm are closed by the control elements
- Prevent and avoid any form of trapping between the moving and fixed parts during manoeuvres
- Permanently affix the manual operation label next to the element enabling the manoeuvre itself
- After installing the drive motor, make sure that the mechanism, protective system and all manual manoeuvres operate properly

2 PRODUCT DESCRIPTION AND INTENDED USE

The devices of this kit and other optional accessories belong to the Nice Home automation system and are designed to automate a swinging gate for residential use.

⚠ CAUTION! – Any use other than that specified herein or in environmental conditions other than those stated in this manual is to be considered improper and is forbidden

The kit comprises two electromechanical gearmotors with 24 V direct current; they are equipped with a key-operated mechanical release mechanism that allows for manually moving the gate in case of a power outage.

A command control unit is included that manages the operation of the entire automation. The control unit is connected to the gearmotors and to the various devices occurs through the ECsbus system (a single cable with 2 wires).

The control unit can be powered by fixed mains power (230 V~) or, alternatively, through the SOLEKIT photovoltaic system of the Nice Home range. If powered from the mains, it can be fitted with a back-up battery (mod. PR100, optional accessory) which ensures that the automation can execute a certain number of manoeuvres during the hours following a power outage.

3 INSTALLATION

Step A

Step B

⚠ Certain devices and accessories mentioned in this manual are optional and not included in the kit.

⚠ The end stops are not included in the kit and do not belong to the Nice Home range of products.

Consult the Nice Home product catalogue or visit the website www.niceforyou.com

3.1 - VERIFYING THE SUITABILITY OF THE GATE AND ENVIRONMENT

- Ensure that the mechanical structure of the gate is suitable for automation and complies with local standards; consult the technical data appearing on the gate's label. **This product cannot automate a gate that is not already secure and efficient; moreover, it cannot resolve defects caused by improper installation of the gate or poor maintenance of the latter.**
- Manually move the gate leaves in the two directions (open/closed) and make sure that the movement takes place with a constant friction at every point along its course (there should be no points requiring more nor less effort).
- If a gate leaf includes an access door, make sure that it does not obstruct normal gate movement; mount a suitable interlock system if necessary.
- Manually bring the door of the gate into any position then leave it closed and make sure that it does not move.
- Check that there is sufficient space where the gearmotors are installed to allow for effecting a manual release manoeuvre.
- Check that the installation surfaces of the various devices are solid for guaranteeing a stable anchorage and that they are protected and guarded against accidental knocks. For the photocells, choose a flat surface capable of guaranteeing proper alignment of the pair (Tx and Rx).

3.2 - VERIFYING THE PRODUCT'S APPLICATION LIMITS

Before proceeding with the installation, carry out the following checks and verify the 'Product technical characteristics' (Paragraph 3.3):

- Check that the estimated durability is compatible with the intended use (Paragraph 9.9.3).
- Ensure that all limitations, conditions and warnings appearing in this manual can be fully observed.

3.3 - PRODUCT TECHNICAL SPECIFICATIONS

Model type	ARIA200M	ARIA400M
Product type	Electromechanical gearmotor for automation of automatic gates and doors	
Technology adopted	A 24 V motor, reducer with helical gears; mechanical release mechanism.	
Maximum inrush torque	1230 Nm	1400 Nm
Nominal torque	300 Nm	300 Nm
Speed (no load)	20 mm/s	16 mm/s
Nominal torque speed	17 mm/s	14 mm/s
Maximum frequency of cycles	15 cycles/hour	15 cycles/hour
Maximum continuous operating time	4 minutes	4 minutes
Application limits	Its structural characteristics make it suitable for use on gates weighing up to 250 kg and for gate leaves up to 2.5 m long.	Its structural characteristics make it suitable for use on gates weighing up to 450 kg and for gate leaves up to 4.5 m long.
Maximum power input	24 W	24 W
Ambient operating temperature	-20°C ... +50°C	
Protection rating	IP44	
Dimensions / weight	846 x 98 h 90 mm / 5 kg	

Model type	CLB202	CLB203
Product type	Control unit for 1 or 2 24 V motors for automation of automatic gates or doors, inclusive of radio receiver for ECCO5... transmitters	
Technology adopted	Electronic board governed by an 8 Bit microcontroller with flash technology. A transformer inside the control unit, but separated from the board, reduces the mains voltage to the nominal 24V voltage used in all of the automation system	
Mains power supply	230 V~ (+10% -15%) 50/60 Hz	
Rated power input	100 W; inrush power is 300 W for a maximum duration of 2 s	
Emergency power supply	Configured for model PR100 back-up batteries	
Flashing light output	For flashing lights with 12 V lamp, maximum 21 W and EL100 interface connection	

ECSbus output	An output with a maximum load of 15 ECSbus units (1 ECSbus unit is equal to the consumption of a pair of photocells)
SbS input	For normally open contacts (closing of the contact triggers the Step-by-Step command)
Stop input	For normally open contacts and/or for 8.2 k Ω constant resistance, or normally closed contacts with self-recognition of the "normal" status (any variation from the memorised status triggers the Stop command)
Radio aerial input	50 Ω for RG58 or similar type of cable
Max. cable length	Mains power supply: 30 m; inputs/outputs: 20 m with antenna cable preferably shorter than 5 m (observe the warnings regarding minimum gauge and type of cables)
Ambient operating temperature	-20°C ... +55°C
Assembly	Vertical, wall-mounted
Protection rating	IP44
Dimensions / weight	180 x 240 h 110 mm / 2.8 kg
Possibility of remote control	Using ECCO5... transmitters, the control unit is able to receive one or more of the following commands: Step-by-Step (SbS) - Partial Open - Open Only - Close Only
Memory capacity	Up to 250 transmitters, if memorised in Mode 1 - 250 keys if memorised in Mode 2
ECCO5... transmitter range	From 50 to 100m. This range can vary if there are obstacles or electromagnetic disturbances, and is affected by the position of the receiving aerial incorporated in the flasher
Programmable functions	"Cycle" or "Complete cycle" (automatic closure) operation "Slow" or "fast" motor speeds Pause time during "complete cycle", selectable from 10, 20, 40, 80 seconds Partial open type selectable in 4 modes Obstacle detection system motor force, with 4 selectable levels Step-by-Step (SbS) command operation selectable in 4 modes
Self-programmed functions	Auto-detection of devices connected to the ECSbus output Auto-detection of the type of Stop device (NO or NC contact or 8.2 k Ω resistor) Auto-detection of the opening angles of each gate leaf Automation auto-detection with 1 or 2 motors

Note: in order to improve its products, NICE S.p.A. reserves the right to modify their technical specifications at any time without prior notice. In any case, the manufacturer guarantees their functionality and suitability for their intended use. Note: all technical specifications refer to a temperature of 20°C.

3.4 - PRE-INSTALLATION WORKS

Consult **Fig. 2** to define the approximate installation position of each device mounted on the system; the various elements are positioned according to a standard and customary layout.

Get all the tools and equipment required to complete the job; check that they are in good condition and that they conform to the local safety provisions.

Laying of electrical cables:

01. Observe **Fig. 2** to understand how the various devices should be connected to the control unit and which terminals should be used for each connection. **▲ Only devices adopting the same technology can be connected to the ECSbus.**

The ECSbus system allows for connecting multiple devices together using – between one device and the next – a single "bus" cable, with 2 internal electrical conductors.

The connection between the devices can have a "cascade", a "star" or a "mixed" configuration, between the first two.

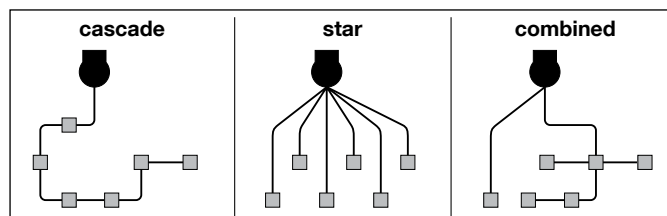

02. Observe **Fig. 2** to understand how to position the electrical cables in the environment (it is advisable to draw on paper a similar layout, adapting it to the relevant requirements).

03. Read **Table 2** to determine the type of cables to be used: **▲ each cable must not exceed the stated maximum length.**

TABLE 2 - Types of electrical cables (see Fig. 2)

Connection	Type of cable	Maximum admissible length
A 230 VAC 50/60 Hz power supply	3 x 1.5 mm ² (not supplied)	30 m *
B Flash flashing light output	2 x 0.5 mm ²	20 m
C Radio aerial	RG58-type shielded cable	20 m (recommended < 5 m)
D ECSbus Input / Output	2 x 0.5 mm ²	20 m **
E Stop input	2 x 0.5 mm ²	20 m **
F SbS (Step-by-Step) input	2 x 0.5 mm ²	20 m **
G Motors M1 and M2 output	3 x 1 mm ²	10 m

* it is possible to use a power cable longer than 30 m, provided that it has a larger gauge (for example, 3 x 2.5 mm²) and is equipped with an earthing device, near the automation.

** For the ECSbus (1) cables and the Stop and SbS inputs, it is also possible to use a single cable with multiple internal conductors, to group multiple connections: for example, the Stop and SbS inputs can be connected to the KS100 selector with a cable measuring 4 x 0.5 mm².

(1) CAUTION! – The ECSbus cables must be positioned in different raceways with respect to the motor cables.

CAUTION! – The cables used must be suited to the installation environment; for example a cable of type H03VV-F for indoor environments, or type H07RN-F for outdoor environments.

3.5 - INSTALLING THE ARIA GEARMOTORS model 200M/400M and CONTROL UNIT model CLB 202/203

- ⚠** • All installation operations must be made with the system disconnected from the power supply. If the back-up battery is present, it must be disconnected
- Incorrect installation may cause serious physical injury to those working on or using the system.
 - Prior to starting, carry out the pre-installation checks stated under Paragraph 3.1.
 - For the system's correct operation, it is necessary to include mechanical stops (not provided with the kit) on the ground or wall, positioned at the maximum opening and closing points of the gate leaf.

3.5.1 - INSTALLING THE ARIA GEARMOTORS 200M/400M

01. Verify the gearmotor's overall dimensions (Phase 01 - Fig. 3).
02. Choose the direction of the bracket to be used based on position "C" (Phase 02 - Fig. 3).
03. Choose position "A" in Table 1 (Phase 03 - Fig. 3).
04. Choose the installation position of the front and rear brackets, then temporarily fasten the rear bracket (Phase 04 - Fig. 3). Check that the supporting surface is solid.
05. If there is no closing stop on the ground, insert the closing limit switch as shown in Phase 05 - Fig. 3.
06. Fasten the gearmotor to the front bracket (Phase 06 - Fig. 3).
07. Position the gearmotor on the rear bracket and secure it with the washer, screw and nut (Phase 07 - Fig. 3).
08. Move the gearmotor until the front bracket rests against the gate leaf, then lock the latter temporarily (Phase 08 - Fig. 3).
09. Manually release the gearmotor (Phase 09 - Fig. 3).
10. Manually perform a few gate leaf opening and closing manoeuvres: check that the nut slides without any particular friction along the gearmotor's rolled ball screw. If necessary, adjust the gearmotor's limit switch by loosening it with the appropriate Allen key and shifting it to the desired position (Phase 10 - Fig. 3).
13. Fasten the brackets permanently on the basis of the type and material of the gate leaf/column (Phase 11 - Fig. 3).
12. Manually lock the gearmotor (Phase 12 - Fig. 3).
14. Repeat the entire operation for the other gearmotor.

3.5.2 - INSTALLING THE CLB 202/203 CONTROL UNIT

01. Install the control unit in an area protected against potential impacts and close to the gate, in order to reduce the overall length of the cables
02. Remove the cover by prying with a screwdriver on the opening at the bottom; slide it a few centimetres then lift it from the bottom (Phase 01 - Fig. 5)
03. Lay the duct for routing the electric cables so that they can be inserted from the lower section of the control unit
04. Drill a hole in the bottom of the control unit and use suitable fittings to fasten the cable ducts (Phase 02 - Fig. 5)
05. Open two holes on the bottom using a screwdriver and mark the drilling points using the bottom for reference; next, drill the wall using a percussion drill with 6 mm bit and insert 6 mm wall plugs. Lastly, fasten the bottom with the relative screws (Phase 03 - Fig. 5)
06. Before closing the control unit, make the electrical connections: see Chapter 4 and Fig. 7
07. To close the cover see Fig. 8.

At this point, it is possible to install the accessories pertaining to the system: for photocells PH200 > Par. 3.6 (Fig. 6) - for flashing light FL200 > Par. 3.7 (Fig. 7). For other optional accessories, consult the respective instruction manuals.

3.6 - INSTALLING THE PHOTOCELLS model PH200 (Fig. 5)



PH200

- ⚠** • position each photocell 40/60 cm above the ground • position them on the opposite sides of the zone to be protected • position them as close as possible to the gate (maximum distance = 15 cm) • a tube for passing the cables must be present in the fastening point • orient the TX transmitter towards the central zone of the RX receiver (allowed misalignment: maximum 5°)

For the installation procedure see Fig. 5.

3.7 - INSTALLING THE FLASHING LIGHT model FL200 (Fig. 6)



FL200

- ⚠** • The flashing light must be positioned near the gate in a clearly visible position. It can be fasted to a horizontal or vertical surface.
- For connection to the Flash terminal, no polarity needs to be observed; instead for connection of the shielded aerial cable, it is necessary to connect the cable and sheath as shown in Fig. 7.

Choose the most suitable position in which to install the flashing light: it must be positioned near the gate in a clearly visible position. It can be fasted to a horizontal or vertical surface.

For the installation procedure see Fig. 6.

4 ELECTRICAL CONNECTIONS

Step C



4.1 - ELECTRICAL CONNECTION TO THE CONTROL UNIT (Fig. 7)

01. Connect the various kit devices and any other components designed for being used on the system (optional and not included in the package) to the control unit terminals (Fig. 7): for all accessories it is not necessary to observe any polarity, with the exception of the shielded aerial cable which must be connected with the cable and sheath as shown. To connect the gearmotors refer to the detail in Fig. 8.

4.2 - POWER SUPPLY CONNECTION

• For operational and programming tests of the automation, use the cable supplied, inserting the plug into an electrical socket. If the socket is a long way from the automation, an extension may be used in this phase.

• For the testing and commissioning phase of the automation (definitive connection) the control unit must be connected permanently to the mains power, by replacing the cable supplied with one of suitable length.

⚠ CAUTION! – The final connection of the system to the mains power or replacement of the cable supplied MUST be performed exclusively by a qualified and electrician, in compliance with local safety standards and the following instructions.

- For installation outdoors, the entire cable must be protected with a protective tube; alternatively, the cable can be replaced with a type H07RN-F cable.
- The power line must be equipped with a device that ensures complete disconnection of the mains power to the automation. The disconnection device must have contacts with a sufficient gap to ensure complete disconnection, under the Category III overvoltage conditions, in accordance with the installation instructions. If necessary, this device guarantees quick and safe disconnection from the mains power and therefore must be positioned in sight of the automation. If located in a concealed position, it must be equipped with a system that prevents inadvertent or unauthorised reconnection of power, to avoid potential hazards.

5 PROGRAMMING

Step D



5.1 - CONTROL UNIT KEYS

The control unit has three programming keys with their respective LEDs: keys P1, P2, P3 and LEDs L1, L2, L3 (Fig. 9)

P1 = radio transmitter memorisation

P2 = slow/fast movement speed selection (Par. 5.6.1)

P3 = semi-automatic/automatic operating cycle selection (Par. 5.6.2)

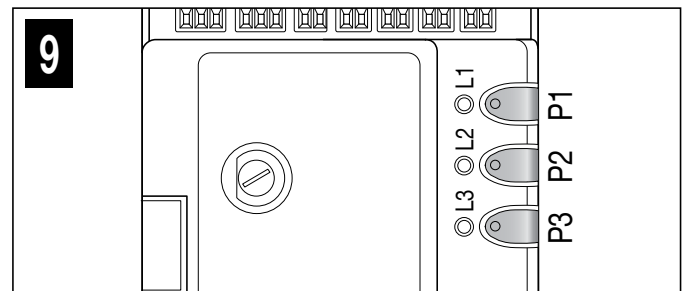

5.2 - PRELIMINARY CHECKS

After powering up the control unit, a few straightforward checks should be carried out:

01. Check on the control unit (Fig. 10) that the ECSbus led flashes normally (roughly one flash each second).

02. On the Tx and Rx photocells (Fig. 11) check that the SAFE led flashes: the type of flash is unimportant as it depends on other factors; however, it is important that the led is not always off or always lit.

03. If all these checks are non-conforming, disconnect the power supply to the control unit and check the relevant connections of the cables. Other useful information is contained in Chapters 9.9 and 10.

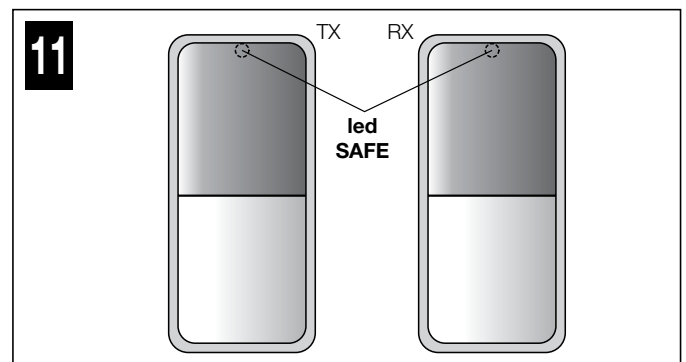
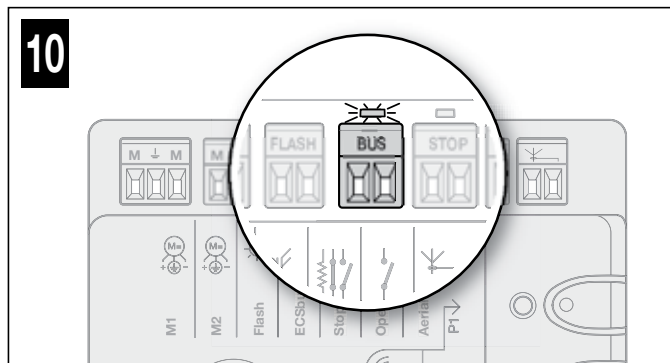

5.3 - MEMORISATION OF CONNECTED DEVICES

On completion of the preliminary checks (Par. 5.2), the control unit must be made to recognise the devices connected on the ECSbus and Stop terminals.

01. On the control unit (Fig. 12) press and hold button P2 for at least 3 seconds then release it.

02. Wait a few seconds for the control unit to complete the device learning phase.

03. On the control unit (Fig. 13), at the end of the recognition procedure, the Stop led must remain lit and led L2 must turn off. The ECSbus led must flash once each second. If led L2 flashes = error (see Chapter 10).

⚠ Whenever a photocell is added to or removed from the system, the recognition procedure for the connected devices must be repeated.

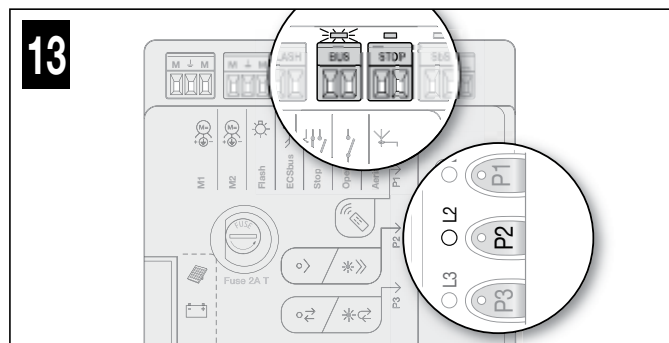
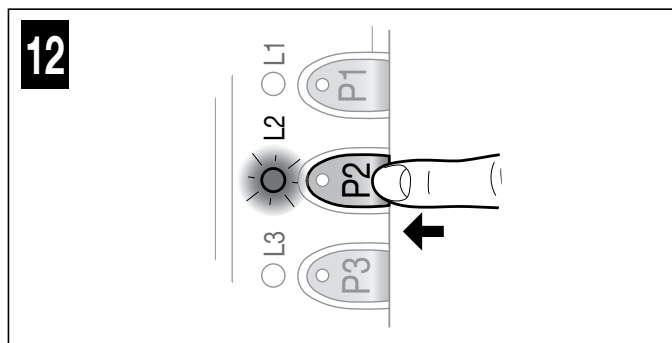

5.4 - MEMORISATION OF GATE LEAF OPENING AND CLOSING ANGLES

After recognition of the devices (Par. 5.3), the control unit must recognise the opening angles of the leaves. In this phase the system reads the leaf opening angle from the mechanical closing stop to the mechanical opening stop. The presence of fixed and sufficiently strong mechanical stops is essential.

01. Manually release the gearmotors (Fig. 14) and bring the gate leaves to midway of their path so that they are free to open and close, then lock the motors (Fig. 15).

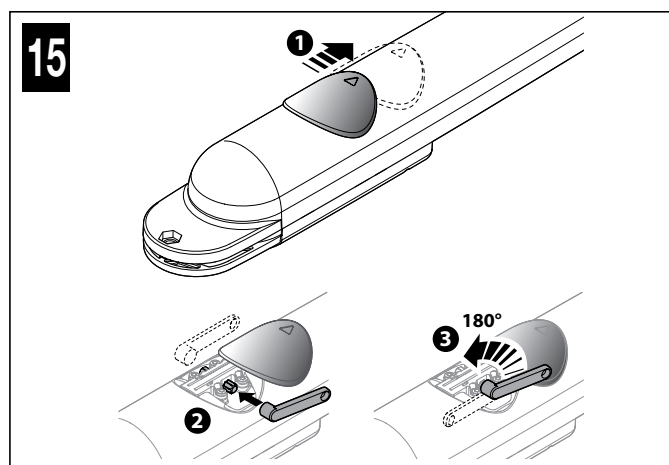
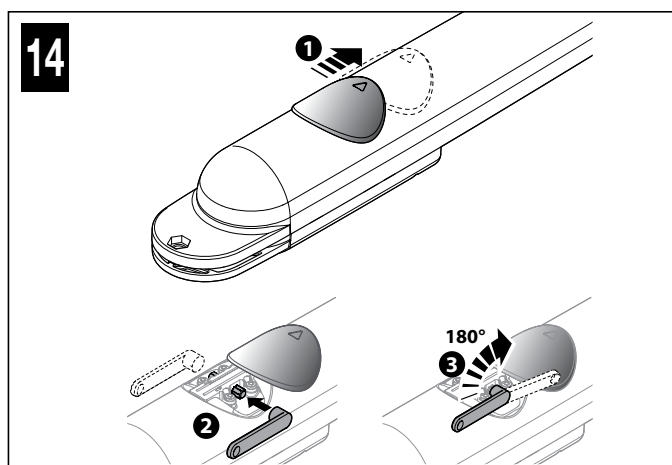

02. On the control unit (Fig. 16) press and release **key P3**: wait for the control unit to perform the memorisation phase: closure of motor M1 up to the mechanical stop, closure of motor M2 up to the mechanical stop, opening of motor M2 and of motor M1 up to the mechanical opening stop; full closure of M1 and M2.

⚠ If the first manoeuvre of one or both of the gate leaves is not a closing movement, press and release **key P3** on the control unit (Fig. 16) to stop the memorisation phase and reverse the polarity of the motor/s that performed the opening, by inverting the brown and blue wires (Fig. 17).

⚠ If the first motor to perform the closing manoeuvre is not M1, press and release **key P3** on the control unit (Fig. 16) to stop the memorisation phase and invert the motor terminals on the control unit (Fig. 18).

⚠ If any device (photocells, keypad, manual pressing of key P3, etc.) intervenes during the memorisation phase, this phase will be immediately stopped: it will have to be repeated entirely.

⚠ If **led L3** flashes at the end of the search for memorised devices, it means that there is an error: see Par. 9.10.3.

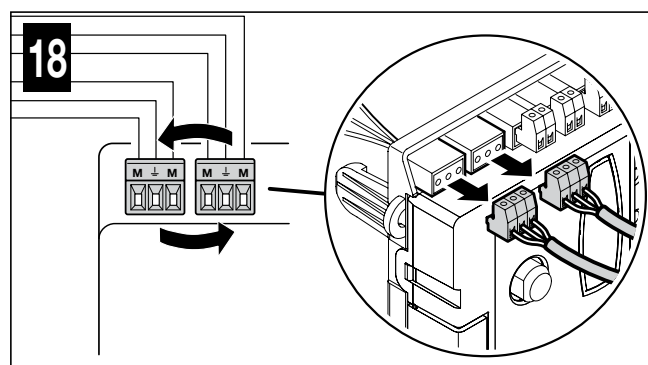
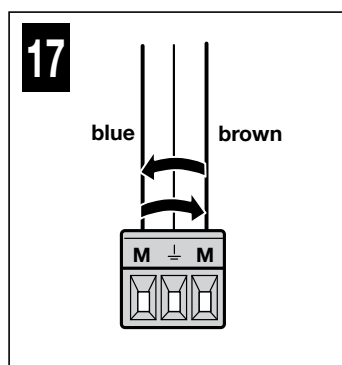
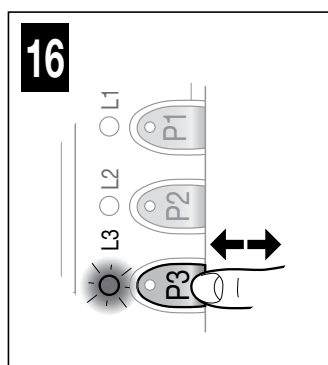

5.5 - MEMORISATION OF THE 1st TRANSMITTER

The control unit incorporates a radio receiver for ECCO5 transmitters (various models): before proceeding with the remaining steps, it is necessary to memorise the 1st transmitter in Mode 1 – see procedure below.

To memorise additional transmitters, see Par. 9.3.

⚠ Before running the memorisation procedure, it is advisable to read it and observe the indicated times.

This procedure allows for simultaneously memorising **all the transmitter keys**, by automatically pairing them to the commands shown in **Table 1** below.

A transmitter memorised in Mode 1 can control only a single automation.

TABLE 1

Keys	Paired command
T1	Step-by-Step (SbS)
T2	Pedestrian opening
T3	Open only
T4	Close only
T5	Not used in this application

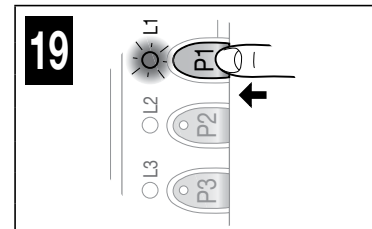
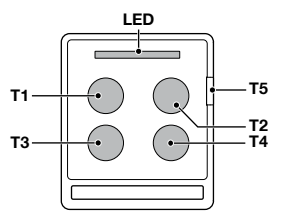

Memorisation procedure

- On the control unit (Fig. 19) press and hold **key P1** for 3 seconds; when **led L1** switches on, release the key.
- Within 10 seconds from releasing it, press and hold for 3 seconds any button of the transmitter to be memorised. If the memorisation procedure was successful, led P1 (on the control unit) will flash 3 times.
- To memorise other transmitters, repeat step 02 within the next 10 seconds otherwise the memorisation phase will terminate automatically.

5.6 - BASIC ADJUSTMENTS

5.6.1 - Choosing the gate leaf manoeuvre speed

The opening and closing manoeuvre speed of the gate leaves can be either "**slow**" or "**fast**" (the type of selection chosen is visualised by the switching on or off of led L2 on the control unit – Fig. 20):

led **L2 off** = the "**slow**" manoeuvre speed was selected.

led **L2 on** = the "**fast**" manoeuvre speed was selected.

Procedure for selecting the desired speed

- Press and release **key P2** several times until **led L2** remains lit or switched off (Fig. 20).

5.6.2 - Choosing the operating cycle of the gate leaf manoeuvre

The type of "opening and closing" manoeuvre cycle of the gate leaves can be either "**single cycle** (semi-automatic)" or "**complete cycle** (automatic)" (the type of selection chosen is visualised by the switching on or off of led L3 on the control unit – Fig. 21):

led **L3 off** = the "**single cycle** (semi-automatic)" manoeuvre cycle was selected (with the first command the gate opens and stays open until the next command that causes it to close).

led **L3 lit** = the "**complete cycle** (automatic)" manoeuvre cycle was selected (with a single command the gate opens and re-closes automatically after a set "pause time" – to adjust the latter see Par. 9.1.1).

Procedure for selecting the desired cycle

- Press and release **key P3** several times until **led L3** remains lit or switched off (Fig. 21).

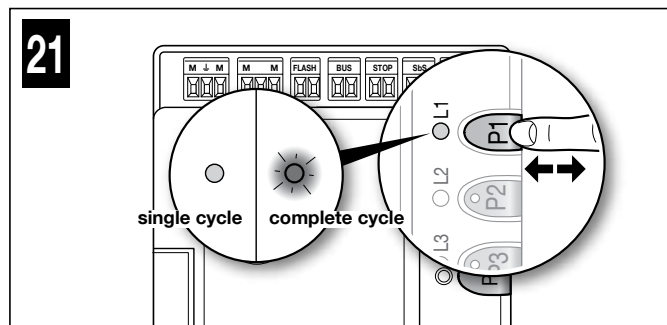
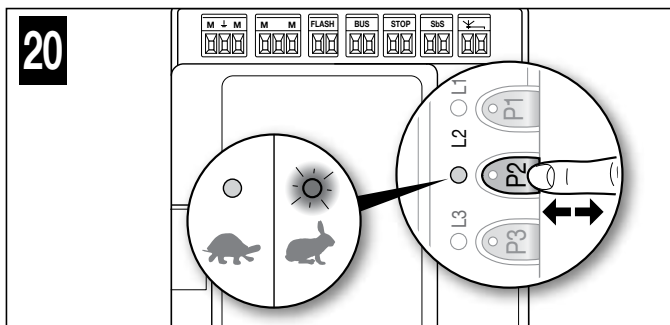



⚠ CAUTION! – The system must be tested by skilled and qualified personnel, who is responsible for defining the tests adopted in relation to the risks present, and for ensuring observance of all legal provisions, standards and regulations, with particular reference to all requirements of the EN 13241-1, EN 12445 and EN 12453 standards which defines the test methods for testing gate automations.

6.1 - TESTING

01. Ensure that all the instructions and warnings indicated in Chapter 1 have been strictly observed.
02. Using the transmitter, test the gate's opening and closing movements and ensure that the leaves move as intended. A number of tests should be performed to ensure that the gate moves smoothly and that there are no assembly defects, incorrect settings, or any points of friction.
03. Check the operation of all the system's safety devices one-by-one (photocells, sensitive edges, etc.) In particular, whenever a device is activated the ECSbus led (on the control unit) must emit a longer flash to confirm that the control unit has recognised the event.
04. To check the photocells and make sure that there is no interference with other devices, pass a cylinder with 5 cm diameter and 30 cm length on the optical axis, first near the TX then near the RX and, lastly, at the mid-point between the two, and verify that in all these cases the device is triggered, switching from the active status to the alarm status and vice-versa; lastly, make sure that it causes the intended action in the control unit; for example: reversal of the movement during the closing manoeuvre.
05. Measure the impact force as specified in the EN 12445 and EN 12453 standards. If the "motor force" control is used as an auxiliary function to reduce the impact force, test and identify the setting that obtains the best results.

6.2 - COMMISSIONING

Commissioning can only be performed after all test phases have been successfully completed. Partial or "makeshift" commissioning is strictly prohibited.

01. Draw up the technical file of the automation which should at least include: assembly drawing (for example as in Fig. 3), wiring diagram (for example Fig. 8), risk analysis and relative solutions adopted, the manufacturer's declaration of conformity for all the devices used.
02. Affix a dataplate on the door, specifying at least the following data: type of automation, name and address of manufacturer (responsible for commissioning), serial number, year of construction and CE marking.
03. Permanently attach to the gate the label supplied in the pack, regarding the procedure for manual locking/release of the gearmotor.
04. Fill in the declaration of conformity and hand it to the owner of the automation (Annex 1).
05. Draw up and hand to the owner of the automation the user guide (Chapter 11 – detachable insert).
06. Prepare and provide the owner with the "Maintenance schedule" form, containing all maintenance instructions for all devices in the automation.
07. Before commissioning the automation, ensure that the owner is properly informed of all risks and hazards still present.

7 MAINTENANCE

Maintenance must be performed in strict observance of the safety provisions in this manual and according to current legislation and standards.

The automation's devices do not require special maintenance; however they should be checked periodically (at least every six months) to ensure complete their full efficiency.

To this aim, run all the tests and checks specified under Paragraph 6.1 and consult the maintenance plan of the respective instruction manuals.

8 PRODUCT DISPOSAL

This product is an integral part of the automation and therefore must be disposed together with the latter.

As in installation, also at the end of product lifetime, the disassembly and scrapping operations must be performed by qualified personnel. This product is made of various types of materials, some of which can be recycled while others must be scrapped. Seek information on the recycling and disposal systems required by local regulations in your area for this product category.

Caution! – certain parts of the product may contain polluting or hazardous substances that, if released into the environment, may seriously damage the environment and human health.

As indicated by the adjacent symbol, the product may not be disposed of together with domestic waste. Separate the waste into categories for disposal, according to the methods set out by legislation in force in your area, or return the product to the retailer when purchasing a new version.



Caution! – local regulations may include the application of heavy fines in the event of improper disposal of this product.

9.1 - ADVANCED SETTINGS

9.1.1 - Adjusting the parameters (using the transmitter memorised in Mode 1)

The transmitter can be used to set a number of control unit operating parameters:

- **Pause time:** time during which the gate leaves remain open before re-closing automatically (if the "complete cycle" function is set); see Par. 9.1.1.1
- **Pedestrian opening:** partial opening mode of the gate leaves, to allow pedestrians to pass through; see Par. 9.1.1.1
- **Motor force:** maximum force applied by the motor to move the gate leaves; when this value is exceeded, the control unit interprets the occurrence as an obstacle stopping the gate leaves and, consequently, inverts the direction of movement; see Par. 9.1.1.1
- **Step-by-Step (SbS) function:** sequence of gate leaf movements associated with each "Step-by-Step" (SbS) command; see Par. 9.1.1.1
- **SbS input configuration:** adjusts the duration of the motor's "short reversion" after the closing manoeuvre is executed, in order to reduce the final residual force; see Par. 9.1.1.2
- **Flash output configuration:** adjusts the duration of the motor's "short reversion" after the opening manoeuvre is executed, in order to reduce the final residual force; see Par. 9.1.1.2
- **Discharging of Motor 1 and Motor 2 upon closing:** adjusts the duration of the motor's "short reversion" after the closing manoeuvre is executed, in order to reduce the final residual force; see Par. 9.1.1.2
- **Discharging of Motor 1 and Motor 2 upon opening:** adjusts the duration of the motor's "short reversion" after the opening manoeuvre is executed, in order to reduce the final residual force; see Par. 9.1.1.2

The adjustment can be effected by means of any transmitter memorised in Mode 1 (as those supplied, see Paragraph 9.3.1). If there is no transmitter memorised in Mode 1, it is possible to memorise one solely for programming purposes then cancelling it (see Paragraph 9.4).

9.1.1.1 - Parameter adjustment procedure: Pause time - Pedestrian opening - Motor force - Step-by-Step function

All parameters can be adjusted as desired, with the exception of the "motor force" parameter, which requires special attention:

- Do not use high force values to compensate for abnormal friction points along the gate's path: excessive force may adversely affect the operation of the safety system or damage the gate itself.
- If the "motor force" control is used to assist the impact force reduction system, measure the force again after each adjustment in compliance with the EN 12445 and EN 12453 standards.
- Weather conditions may affect the movement of the gate, so the latter should be readjusted periodically.

⚠ Before proceeding, check the parameter to be modified in Table 2 and the action to be performed:

- 01.** On the transmitter (Fig. 22) simultaneously press and hold **buttons T1 and T2** for 5 seconds then release them.
- 02.** Within **3 seconds** from releasing them, perform the action specified in **Table 2** to modify the desired parameter.

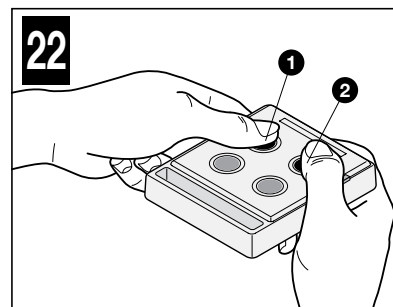
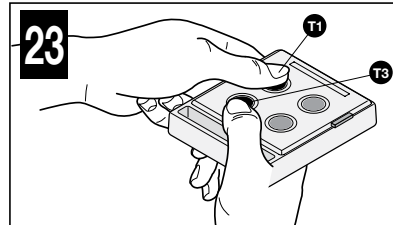

TABLE 2

Parameters	Value	No. of flashes emitted by the flashing light	Transmitter key to be used	Actions to be performed
Pause time	10 sec	1	T1	Press T1 once
	20 sec *	2	T1	Press T1 twice
	40 sec	3	T1	Press T1 three times
	80 sec	4	T1	Press T1 four times
Pedestrian opening	Opening to midway of gate leaf 1	1	T2	Press T2 once
	Full opening of gate leaf 1 *	2	T2	Press T2 twice
	1/4 opening of the two leaves	3	T2	Press T2 three times
	Midway opening of the two leaves	4	T2	Press T2 four times
Motor force	Low	1	T3	Press T3 once
	Medium-low *	2	T3	Press T3 twice
	Medium-high	3	T3	Press T3 three times
	High	4	T3	Press T3 four times
Step-by-Step (SbS) function	Open - Stop - Close - Stop	1	T4	Press T4 once
	Open - Stop - Close - Open *	2	T4	Press T4 twice
	Open - Close - Open - Close	3	T4	Press T4 three times
	Opening only	4	T4	Press T4 four times

* Factory value

9.1.1.2 - Parameter adjustment procedure: SbS input configuration - Flash output configuration - Discharging of Motor 1 and 2 upon closing - Discharging of Motor 1 and 2 upon opening



⚠ Before proceeding, check the parameter to be modified in Table 3 and the action to be performed:

- 01.** On the transmitter (Fig. 23) simultaneously press and hold **keys T1 and T3** for 5 seconds then release them.
- 02.** Within 3 seconds from releasing them, perform the action specified in **Table 3** to modify the desired parameter.

TABLE 3				
Parameters	Value	No. of flashes emitted by the flashing light	Transmitter key to be used	Actions to be performed
SbS input configuration	Step-by-step *	1	T1	Press T1 once
	Pedestrian opening	2	T1	Press T1 twice
Flash output configuration	Flashing light *	1	T2	Press T2 once
	Courtesy light	2	T2	Press T2 twice
	Gate open indicator	3	T2	Press T2 three times
Discharging of Motors 1 and 2 upon closing	No discharge *	1	T3	Press T3 once
	0.1 sec (minimum)	2	T3	Press T3 twice
	0.2 sec	3	T3	Press T3 three times
	0.3 sec	4	T3	Press T3 four times
	0.4 sec (average)	5	T3	Press T3 five times
	0.5 sec	6	T3	Press T3 six times
	0.6 sec	7	T3	Press T3 seven times
	0.7 sec (maximum)	8	T3	Press T3 eight times
Discharging of Motors 1 and 2 upon when gate opens	No discharge *	1	T4	Press T4 once
	0.1 sec (minimum)	2	T4	Press T4 twice
	0.2 sec	3	T4	Press T4 three times
	0.3 sec	4	T4	Press T4 four times
	0.4 sec (average)	5	T4	Press T4 five times
	0.5 sec	6	T4	Press T4 six times
	0.6 sec	7	T4	Press T4 seven times
	0.7 sec (maximum)	8	T4	Press T4 eight times

* Factory value

9.1.2 - Verifying the values set for each parameter (using the transmitter memorised in Mode 1)

The check can be effected by means of any transmitter memorised in Mode 1 (as those supplied, see Paragraph 9.3.1). If there is no transmitter memorised in Mode 1, it is possible to memorise one solely for programming purposes then cancelling it (see Paragraph 9.4).

9.1.2.1 - Parameter verification procedure: Pause time - Pedestrian opening - Motor force - Step-by-Step (SbS) function

⚠ Before proceeding, check the parameter to be modified in Table 4 and the action to be performed:

- 01.** On the transmitter (Fig. 24) simultaneously press and hold **buttons T1 and T2** for 5 seconds then release them.
- 02.** Within 3 seconds from releasing them, perform the action specified in **Table 4** to verify the desired parameter.
- 03.** Release the key when the flashing light starts flashing: count the flashes.
Check in Table 2 the value corresponding to the number of flashes.

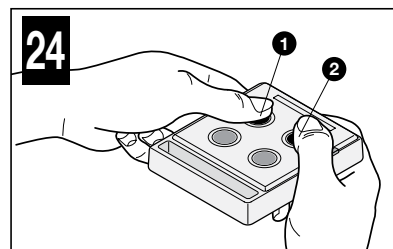

TABLE 4	
Parameters	Actions to be performed
Pause time	Press and hold key T1
Pedestrian opening	Press and hold key T2
Motor force	Press and hold key T3
Step-by-Step function	Press and hold key T4

9.1.2.2 - Parameter verification procedure: Discharging of Motor 1 upon closing - Discharging of Motor 1 upon opening - Discharging of Motor 2 upon closing - Discharging of Motor 2 upon opening

⚠ Before proceeding, check the parameter to be modified in Table 5 and the action to be performed:

- 01.** On the transmitter (Fig. 25) simultaneously press and hold **keys T1 and T3** for 5 seconds then release them.
- 02.** Within 3 seconds from releasing them, perform the action specified in **Table 5** to verify the desired parameter.
- 03.** Release the key when the flashing light starts flashing: count the flashes.
Check in Table 3 the value corresponding to the number of flashes.

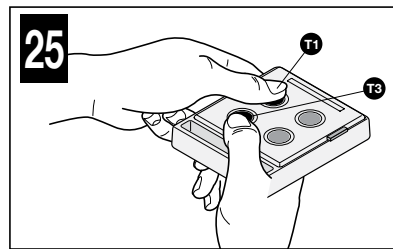

TABLE 5	
Parameters	Actions to be performed
Discharging of Motor 1 upon closing	Press and hold key T1
Discharging of Motor 1 upon opening	Press and hold key T2
Discharging of Motor 2 upon closing	Press and hold key T3
Discharging of Motor 2 upon opening	Press and hold key T4

9.2 - ADDING OR REMOVING DEVICES

It is possible to add or remove devices at any time to the system: if devices are added, it is important to verify that these are perfectly compatible with ARIA 200M/400M; for further details contact the Nice technical support service.

9.2.1 - Memorising additional devices

The recognition operation of the devices connected to the ECSbus and to the Stop input is usually carried out during the installation phase; but if devices are added (or removed) subsequently, the following procedure must be carried out:

01. On the control unit press and hold **button P2 (Fig. 26)** for at least 3 seconds then release it.
02. Wait a few seconds until the control unit has completed the device recognition procedure: led L2 switches off. If instead it flashes, it means that there is some error – see Chapter 10.
03. After adding or removing devices, the automation must be tested again (Par. 6.1).

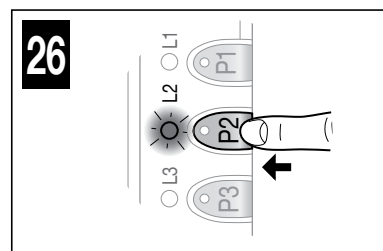

9.3 - MEMORISING ADDITIONAL TRANSMITTERS

The control unit incorporates a radio receiver for ECCO5 transmitters (various models). The transmitters supplied are not memorised, therefore it is first necessary to memorise the 1st transmitter (Par. 5.5); to memorise additional transmitters, it is possible to choose one of the procedures (Mode 1 or Mode 2) indicated below. The control unit can memorise a total of 250 units: memorisation in Mode 1 occupies one unit of memory for each transmitter, while the Mode 2 procedure occupies one unit of memory for each transmitter key.

⚠ Before carrying out the memorisation procedures, we recommend reading them and observing the indicated times.

9.3.1 - Mode 1 memorisation procedure

This procedure allows for simultaneously memorising all the transmitter keys, by automatically pairing them to the commands shown in **Table 6**. **A transmitter memorised in Mode 1 can control only a single automation.**

Keys	Paired command
T1	Step-by-step
T2	Partial open
T3	Open only
T4	Close only

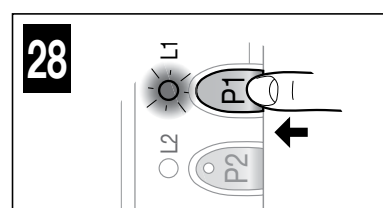
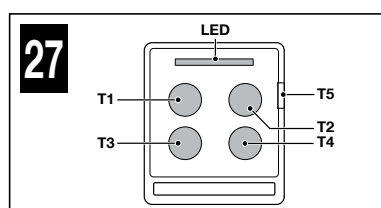

Memorisation procedure

01. **On the control unit (Fig. 28)** press and hold **key P1** for 3 seconds; when **led L1** switches on, release the key.
02. Within 10 seconds from releasing it, press and hold for 3 seconds any key of the transmitter to be memorised (excluding key T5 - Fig. 27).
If the memorisation procedure was successful, led L1 (on the control unit) will flash 3 times.
03. To memorise other transmitters, repeat step 02 within the next 10 seconds otherwise the memorisation phase will terminate automatically.

9.3.2 - Mode 2 memorisation procedure

This procedure allows for memorising one key at a time, by pairing one of the desired commands shown in **Table 7**.

A transmitter memorised in Mode 2 can control multiple automations (for example: automation 1 controlled by key 1; automation 2 controlled by key 2; and so forth)

No. of key presses	Paired command	No. of flashes of led L1 on the control unit
once	Step-by-step	1
twice	Pedestrian opening	2
3 times	Open only	3
4 times	Close only	4
5 times	Stop	5
6 times	Condominium open	6
7 times	High priority open	7
8 times	Pedestrian opening 2	8
9 times	Pedestrian opening 3	9
10 times	Open + lock automation	10
11 times	Close + lock automation	11
12 times	Lock automation	12
13 times	Release automation	13

Memorisation procedure

01. **Before proceeding, it is necessary to cancel the memory of the transmitter to be memorised – see Par. 9.4.**
02. In **Table 7**, choose the command and the number of press-down actions to be effected on the desired transmitter key.
03. **On the control unit (Fig. 28)** press and release **key P1** for a number of times corresponding to the chosen command (Table 5); **led L1** must emit a number of fast flashes corresponding to the chosen command.
04. Within 10 seconds, press and hold for 2 seconds the key of the transmitter to be memorised: if the memorisation was successful, **led L1** (on the control unit) will flash 3 times.
05. To memorise other transmitters, with the same command, repeat step 03 within 10 seconds, otherwise the memorisation phase will terminate automatically.

9.3.3 - Memorisation procedure near the control unit with two transmitters (without using the control unit keys)

With this procedure a NEW transmitter is memorised using a second transmitter (OLD) already memorised and operating, without using the keys of the control unit but drawing close to the latter.

During the procedure the NEW transmitter is memorised in the same way that the OLD transmitter was memorised (Mode 1 or Mode 2).

• Procedure with OLD transmitter memorised in Mode 1:

01. Draw near the control unit with the two transmitters: **⚠ wait 1 second between two successive steps.**
02. **On the NEW transmitter**, press and hold any key for at least **8 seconds** then release it.
03. **On the OLD transmitter**, press and hold any key to be copied for at least **2 seconds** then release it.
04. **On the OLD transmitter**, press and hold any key to be copied for at least **2 seconds** then release it.
05. **On the OLD transmitter**, press and hold any key to be copied for at least **2 seconds** then release it.

06. On the NEW transmitter, press and hold any key to be memorised for at least **5 seconds** then release it.

Repeat the procedure for each transmitter to be memorised.

• Procedure with OLD transmitter memorised in Mode 2:

01. Draw near the control unit with the two transmitters: **⚠ wait 1 second between two successive steps.**

02. On the NEW transmitter, press and hold the key to be memorised for at least **8 seconds** then release it.

03. On the OLD transmitter, press and hold the key to be copied for at least **2 seconds** then release it.

04. On the OLD transmitter, press and hold the key to be copied for at least **2 seconds** then release it.

05. On the OLD transmitter, press and hold the key to be copied for at least **2 seconds** then release it.

06. On the NEW transmitter, press and hold the key to be memorised for at least **5 seconds** then release it.

Repeat the procedure for each transmitter to be memorised.

9.4 - DELETING THE MEMORY OF THE INDIVIDUAL TRANSMITTER FROM THE CONTROL UNIT'S MEMORY

This procedure allows for cancelling a single transmitter (memorised in Mode 1) or only one of its keys (memorised in Mode 2): it is necessary to arrange the transmitter to be cancelled and simultaneously be able to access the control unit (before proceeding, open the gearmotor – Fig. 9).

• Procedure with transmitter memorised in Mode 1:

01. On the control unit (Fig. 29) press and hold **key P1 until the end of the procedure.**

02. When **led L1** lights up, while keeping key P1 pressed, also press and hold **any key** of the transmitter to be cancelled, until **led L1** flashes 5 times, then release both keys.

Repeat the procedure for each transmitter to be cancelled.

• Procedure with transmitter memorised in Mode 2:

01. On the control unit (Fig. 29) press and hold **key P1 until the end of the procedure.**

02. When **led L1** lights up, while keeping key P1 pressed, also press and hold **the key** of the transmitter to be cancelled, until **led L1** flashes 5 times, then release both keys

Repeat the procedure for each transmitter to be cancelled.

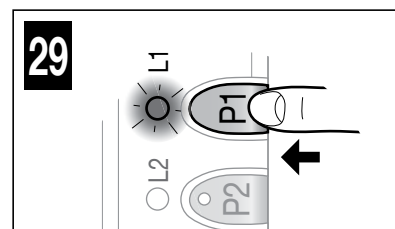

9.5 - COMPLETE DELETION OF THE RADIO MEMORY

This procedure allows for cancelling ALL memorised transmitters: the procedure must be carried out on the control unit (before proceeding, open the cover of the gearmotor – Fig. 9).

01. On the control unit (Fig. 29) press and hold **key P1.**

02. Check that **led L1** lights up for 4/5 seconds, that it switches off then flashes 3 times.

03. Release **key P1** precisely at the 3rd flash.

04. Check that **led L1** emits very fast flashes.

05. Check that **led L1** emits 5 slow flashes = deletion completed.

9.6 - INSTALLING THE BACK-UP BATTERY (model PR100)

⚠ CAUTION! - The electrical connection of the back-up battery to the control unit **must be made exclusively after completing all the installation and programming stages, as the battery is an emergency power supply.**

To install the back-up battery and connect it to the control unit, see **Fig. 30** and consult the respective instruction manual.

When the automation is powered by the back-up battery, 60 seconds after a manoeuvre is completed the control unit automatically switches off the ECSbus output (and all devices connected to it), the Flash output and all LEDs (with the exception of the ECSbus led, which flashes more slowly): this automatic switching off is the "Standby" function.

Subsequently, when the control unit receives a command, the normal operating mode is restored with a short delay; this function is used to reduce consumption (very important when the automation is powered by a battery)

9.7 - INSTALLING THE SOLAR POWER SYSTEM KIT model SOLEKIT

⚠ CAUTION! - When the automation mechanism is powered exclusively by the solar power supply system, **IT MUST NOT BE POWERED by the electricity grid at the same time.**

To connect the SOLEKIT solar power supply system to the control unit, see **Fig. 31** and consult the relevant instruction manual.

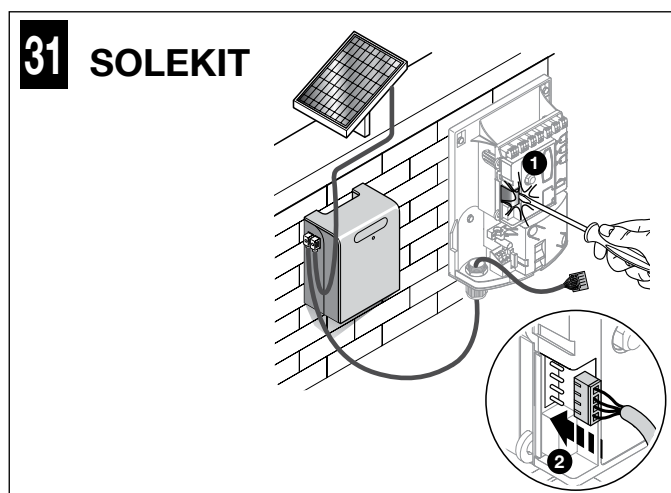
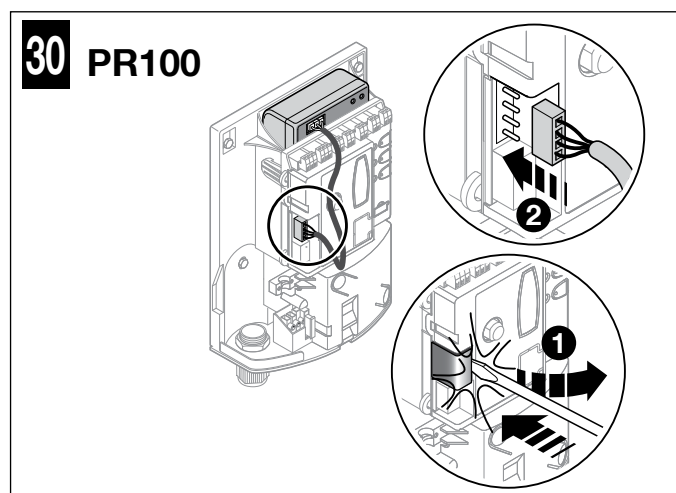

9.8 - DIAGNOSTICS AND DEVICE SIGNALS

Certain devices are configured to display messages to identify their operating status or any anomalies.

9.8.1 - Photocell signals

The photocells contain a SAFE led (**Fig. 32**) that allows for verifying their operating status at any time: see **Table 8**.

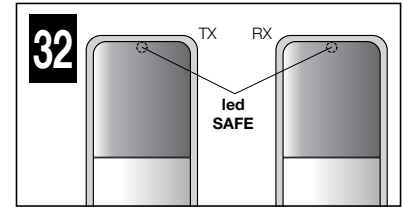

TABLE 8

SAFE led (Fig. 32)	Status	Action
Off	The photocell is not powered or is faulty	Check that the voltage on the photocell terminals is around 8–12 VDC; if the voltage is correct, the photocell is probably faulty
3 quick flashes and 1 second pause	Device not recognised by the control unit	Repeat the recognition procedure on the control unit. Check that all pairs of photocells on the ECSbus have different addresses (consult the instruction manual of the photocells)
1 very slow flash	The RX receives an excellent signal	Normal operation
1 slow flash	The RX receives a good signal	Normal operation
1 quick flash	The RX receives a poor signal	Normal operation but check TX-RX alignment and correct cleaning of photocell lenses
1 very quick flash	The RX receives a bad signal	At the limit of normal operation; check TX-RX alignment and correct cleaning of photocell lenses
Always lit	The RX does not receive any signal	Check for any obstruction between TX and RX. Check that the led on TX emits a slow flash. Check the TX-RX alignment

9.8.2 - Flashing light signals

During the manoeuvre, the flashing light emits 1 flash each second; when there is an anomaly, it flashes quickly: see **Table 9**.

TABLE 9

Flashes (quick)	Status	Action
1 flash 1 second pause 1 flash	Error on the ECSbus	At the beginning of the manoeuvre the devices present do not match those recognised; check and, if necessary, try running the recognition procedure (Par. 9.2.1). One or more devices may be faulty; check and, if necessary, replace them
2 flashes 1 second pause 2 flashes	Intervention of a photocell	At the start of the manoeuvre, one or more photocells do not enable movement; check to see if there are any obstructions. During the movement, if the obstacle is effectively present, no action is required
3 flashes 1 second pause 3 flashes	“Gearmotor force” limiting device activated	During the movement, the gate experienced excessive friction; identify the cause
4 flashes 1 second pause 4 flashes	Intervention of the Stop input	At the start of the manoeuvre or during the movement, the Stop input intervened; identify the cause

9.8.3 - Control unit signals

On the control unit there are LEDs (**Fig. 8**) that emit signals both during normal operation and in case of anomalies: see **Table 10**.

TABLE 10

ECSbus led	Status	Action
Off	Fault	Verify whether there is power and whether the fuses are blown; in this case, identify the reason for the failure then replace them with others of the same type
On	Serious fault	There is a serious fault; try switching off the control unit for a few seconds; if the condition persists, it means that there is a malfunction and the electronic circuit board has to be replaced
1 flash per second	All OK	Control unit works correctly
2 long flashes	Input status variation	This is normal when there is a change in one of the inputs: SbS, Stop, intervention of photocells or the radio transmitter is used
1 flash every 5 seconds	Automation in “standby” mode	All OK; when a command arrives, the control unit will restore normal operation (after a brief delay)
Series of flashes separated by a pause	Flashing light signal see Table 9	An overload has been detected therefore the power to the ECSbus was switched off. To verify, disconnect one device at a time.
Quick flash	ECSbus short-circuit	To activate power to the ECSbus, simply give a command (for example, through the transmitter)
Stop led	Status	Action
Off *	Intervention of the Stop input	Check the devices connected to the Stop input
On	All OK	Stop input active
SbS led	Status	Action
Off	All OK	SbS input not active
On	Intervention of the SbS input	Normal only if the device connected to the SbS input is actually active
Led L4	Status	Action
Off *	All OK	No Memorisation in progress

On	Memorisation in Mode 1	During memorisation in Mode 1, it is normal for it to last maximum 10 seconds.
A series of quick flashes (from 1 to 4)	Memorisation in Mode 2	During memorisation in Mode 2, it is normal for it to last maximum 10 seconds.
5 quick flashes	Deletion OK	Successful deletion of a transmitter
1 slow flash	Incorrect command	A command has been received from a non-memorised transmitter
3 slow flashes	Memorisation OK	Memorisation completed successfully
5 slow flashes	Deletion OK	Deletion of all transmitters completed successfully
L2 led	Status	Action
Off *	All OK	"Slow" speed selected
On	All OK	"Fast" speed selected
1 flash per second	The device recognition phase has not been carried out, or there are errors in the memorised data	Perform the position recognition phase again (see Par. 5.4)
2 flashes per second	Device recognition phase in progress	Indicates that the search phase for connected devices is under way (it lasts a few seconds at the most)
L3 led	Status	Action
Off *	All OK	Cycle operation
On	All OK	Complete-cycle operation

*** or it could be in "Standby" mode**

9.9 - SPECIFICATIONS

9.9.1 - ECSbus system

ECSbus is a system that allows for connecting ECSbus devices using just two wires, which convey both electricity and communication signals. All the devices are connected in parallel on the two ECSbus wires; each device is recognised individually by the control unit, thanks to an unambiguous address assigned to each device during installation.

Photocells and other devices adopting this system can be connected to the ECSbus, such as safety devices, control buttons, indicator lights etc. For information on ECSbus devices, consult the Nice Home range product catalogue or visit the website www.niceforyou.com

Through a recognition procedure the control unit recognises one-by-one all the devices connected and this enables it to detect with extreme precision all possible anomalies during the automation's normal operation. For this reason, whenever a device connected to the ECSbus is added or removed, it is necessary to repeat the recognition procedure for these additional devices (Par. 9.2.1).

9.9.2 - Stop input

The Stop input causes the immediate stoppage and a brief inversion of the manoeuvre; both devices with normally open (NO) contacts and devices with normally closed (NC) contacts can be connected to this input, as well as devices with 8.2 k Ω constant resistance (e.g. sensitive edges). With suitable arrangements, multiple devices – even of different type – (read **Table 11**) can be connected to the Stop input.

		1 st -type device:		
		NO	NC	8.2 k Ω
2 nd -type device:	NO	In parallel (Note 2)	(Note 1)	In parallel
	NC	(Note 1)	In series (Note 3)	In series
	8.2 k Ω	In parallel	In series	(Note 4)

Note 1: the NO and NC combination is possible by wiring the 2 contacts in parallel, while making sure that a 8.2 k Ω resistor is connected in series with the NC contact (therefore, it is also possible to combine 3 devices: NO, NC and 8.2 k Ω).

Note 2: multiple NO devices can be connected in parallel to each other without any quantity limit.

Note 3: multiple NC devices can be connected in series to each other without any quantity limit.

Note 4: only 2 devices with 8.2 k Ω constant resistance output can be connected in parallel; if required, multiple devices must be connected in "cascade" mode with a single 8.2 k Ω termination resistance.

CAUTION! – If the Stop input is used to connect devices with safety functions, only the devices with 8.2 k Ω constant resistance output guarantee Category 3 safety against faults.

Similarly to the ECSbus, the control unit recognises the type of device connected to the Stop input when the recognition procedure is carried out. Subsequently, the system triggers a STOP when any variation occurs with respect to the recognised status.

9.9.3 - Product durability

Durability is the average economic lifespan of the product. The durability value is strongly influenced by the degree of severity of the manoeuvres, in other words, the sum of all factors that contribute to product wear (Table 10). To estimate the life span of your automated device, proceed as follows:

01. Add up all the values of the entries in **Table 12**;

02. In **Graph 1**, from the value obtained above, trace a vertical line until it intersects the curve; from this point trace a horizontal line until it intersects the line of the "manoeuvre cycles". The value obtained is the estimated lifetime of your product.

The durability values specified in the graph are only obtainable if the maintenance schedule is strictly observed (Chapter 7). The lifetime is estimated on the basis of design calculations and the results of tests performed on prototypes. Being only an estimate, it does not constitute any form of guarantee on the actual lifespan of the product.

Example of durability calculation: automation of a gate with a door 1.5 m long with a weight of 220 kg, installed in a windy area. Table 1 shows the "severity indices" for this type of installation: 10% ("Door length"), 20% ("Door weight") and 15% ("Installation in windy area"). These indicators must be added together to obtain the overall severity index, which in this case is 45%.

With the value identified (45%), look at the horizontal axis of Graph 2 ("severity index"), and identify the value corresponding to the number of "manoeuvre cycles" our product will be able to perform in its lifespan, about 55,000 cycles.

TABLE 12		Severity index	
		ARIA200M	ARIA400M
Weight of the leaf	> 100 kg	10%	10%
	> 200 kg	20%	20%
	> 300 kg	-	30%
	> 400 kg	-	40%
Length of the leaf	1 – 1.5 m	10%	-
	1.5 – 2.5 m	20%	-
	2.5 – 3.5	-	20%
	3.5 – 4.5	-	30%
Ambient temperature greater than 40°C or lower than 0°C, or humidity greater than 80%		20%	20%
Solid leaf		15%	15%
Installation in suction cup area		15%	15%

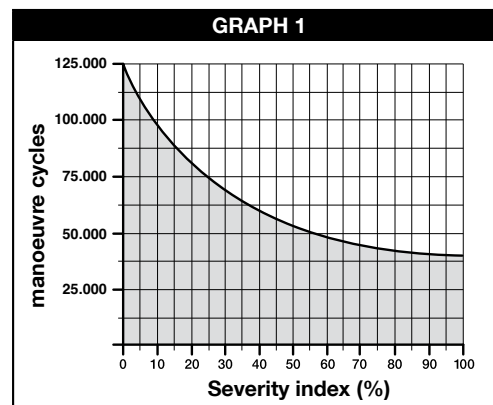

10 TROUBLESHOOTING

Table 15 contains useful information to help solve any malfunctions that may occur during installation or in case of a fault.

TABLE 15	
Symptoms	Probable cause and possible solution
The radio transmitter does not emit any signal and the corresponding led fails to light up	Check the batteries: if they are flat, replace them (consult the transmitter's instruction manual).
The manoeuvre fails to start and the ECSbus led on the control unit does not flash	<ul style="list-style-type: none"> • Check that the power cable is correctly inserted in the power outlet. • Check the fuses; if they have tripped, determine the cause of the fault and replace them with others of the same type: see Fig. 33.
The manoeuvre fails to start and the automation's flashing light is off	Check that the command is actually received. If the command reaches the SbS input, the relevant SbS led lights up; if a transmitter is used, the ECSbus led must emit 2 long flashes.
The manoeuvre fails to start and the automation's flashing light emits a few flashes	<ul style="list-style-type: none"> • Check that the Stop input is active (in other words, that the Stop led is lit). Should this not be the case, check the device connected to the Stop input. • The photocells test (which the control unit performs at the start of each manoeuvre) failed: check the photocells, by verifying their status in Table 8.
The manoeuvre starts but is immediately followed by a reverse run commanded by the control unit	The programmed "motor force" setting is too low to move the gate. Check whether there are any obstacles obstructing the gate's movement and, if necessary, select a higher force as described in Par. 9.1.1.
The manoeuvre is carried out but the flashing light is not working	During the manoeuvre, check that the Flash terminal of the flashing light is powered (being intermittent, the voltage value is irrelevant: roughly 10–30 V $\overleftrightarrow{=}$); if it is powered, the problem is due to the lamp not working (consult the flashing light's instruction manual to replace it).

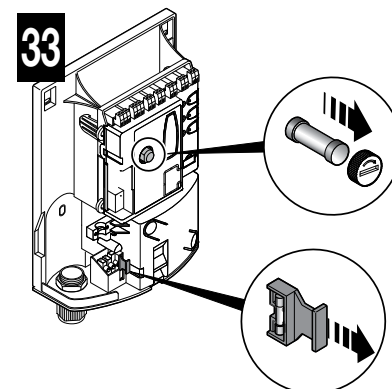

EC Declaration of Conformity

Declaration in accordance with the following Directives: 1999/5/EC (R&TTE), 2014/30/EU (EMC); 2006/42/EC (MD) Annex II, Part B

Note - The contents of this declaration correspond to that stated in the official document filed in the offices of Nice S.p.A. and, in particular, the latest version thereof available prior to the printing of this manual. The text herein has been re-edited for editorial purposes. A copy of the original declaration can be requested from Nice S.p.A. (TV) Italy.

Number: 580/ARIA

Revision: 0

Language: EN

Manufacturer's name: NICE S.p.A. - **Address:** Via Pezza Alta N°13, 31046 Rustignè di Oderzo (TV), Italy - **Person authorised to draw up the technical documentation:** NICE S.p.A. - **Product type:** 24 VDC gearmotor for swinging gates - **Model / Type:** ARIA200M, ARIA400M, CLB202, CLB203 - **Accessories:** PR100, ECCO5BO, ECCO5WO, PH200, FL200

The undersigned, Roberto Griffa, as Chief Executive Officer, hereby declares under his own responsibility that the product identified above complies with the provisions of the following directives:

Models CLB202 and CLB203 conform to DIRECTIVE 1999/5/EC OF THE EUROPEAN PARLIAMENT AND OF THE COUNCIL of 9 March 1999 on radio equipment and telecommunications terminal equipment and the mutual recognition of their conformity, in accordance with the following harmonised standards:

- Health and safety (Art. 3(1)(a)): EN 62479:2010
- Electrical safety: (Art. 3(1)(a)): EN 60950-1:2006+A11:2009+A12:2011+A1:2010+A2:2013
- Electromagnetic compatibility: (Art. 3(1)(b)): EN 301 489-1 V1.9.2:2011, EN 301 489-3 V1.6.1:2013
- Radio spectrum: (Art. 3(2)): EN 300 220-2 V2.4.1:2012

Models ARIA200M, ARIA400M, CLB202 and CLB203 conform to DIRECTIVE 2014/30/EU OF THE EUROPEAN PARLIAMENT AND OF THE COUNCIL of 26 February 2014 on the harmonisation of the laws of the Member States relating to electromagnetic compatibility (recast), in accordance with the following harmonised standards: EN 61000-6-2:2005, EN 61000-6-3:2007 + A1:2011

Models ARIA200M, ARIA400M, CLB202 and CLB203 conform to DIRECTIVE 2014/35/EU OF THE EUROPEAN PARLIAMENT AND OF THE COUNCIL of 26 February 2014 on the harmonisation of the laws of Member States relating to the making available on the market of electrical equipment designed for use within certain voltage limits (recast), according to the following harmonised standards:

EN 60335-1:2002 + A1:2004 + A11:2004 + A12:2006 + A2:2006 + A13:2008 + A14:2010 + A15:2011; EN 60335-2-103:2003+A11:2009, EN 62233:2008

In addition, models ARIA200M, ARIA400M, CLB202 and CLB203 conform to the following directive in accordance with the provisions applicable to partly completed machinery:

Directive 2006/42/EC OF THE EUROPEAN PARLIAMENT AND COUNCIL of May 17 2006 regarding machines and amending Directive 95/16/EC (recast)

- It is hereby declared that the relevant technical documentation has been compiled in accordance with Annex VII Part B of Directive 2006/42/CE and that the following essential requirements have been applied and fulfilled: 1.1- 1.1.2- 1.1.3- 1.2.1-1.2.6- 1.5.1-1.5.2- 1.5.5- 1.5.6- 1.5.7- 1.5.8- 1.5.10- 1.5.11

- The manufacturer undertakes to transmit, in response to a reasoned request by the national authorities, relevant information on the partly completed machinery. This shall be without prejudice to the intellectual property rights of the manufacturer of the partly completed machinery.

- Should the partly completed machinery be put into service in a European country with an official language different to the one used in this declaration, a translation into that language must be provided by the person bringing the machinery into the language area in question.

- The partly completed machinery may not be put into service until the final machinery into which it is to be incorporated has been declared in conformity with the provisions of Directive 2006/42/EC, where appropriate.

Moreover, models ARIA200M, ARIA400M, CLB202 and CLB203 conform – limitedly to the applicable parts – to the following standards:

EN 13241-1:2003 + A1:2011, EN 12445:2000, EN 12453:2000, EN 12978:2003 + A1:2009

Oderzo, 24 August 2016

Mr. Roberto Griffa
 (Chief Executive Officer)

11 USER MANUAL (to be delivered to the end user)

⚠ This user guide should be stored and handed to all user's of the automation.

11.1 – WARNINGS

- Monitor the gate while it is moving and keep at a safe distance until it is fully open or closed; do not transit through it until the gate is fully open and stopped.
- Do not let children play near the gate or with its commands.
- Keep the transmitters away from children.
- Suspend the use of the automation immediately as soon as you notice something abnormal in the operation (noises or jolting movements); failure to follow this warning may cause serious danger and accidents.
- Do not touch moving parts.
- Regular maintenance checks must be carried out by qualified personnel according to the maintenance plan.
- Maintenance or repairs must only be carried out by qualified technical personnel.
- Send a command with the safety devices disabled:

If the safety devices do not work properly or are out of order, the gate can still be operated.

01. Activate the gate control with the transmitter or the devices connected to the SbS terminal. If the safety devices give the enable signal, the gate opens normally; otherwise, reattempt within 3 seconds and keep the control activated.
02. After approximately 2 seconds the gate will start moving in the "man present" mode, that is, so long as the control is kept activated the gate will keep moving; as soon as the control is released the gate will stop.

If the safety devices are out of order, arrange to repair the automation as soon as possible.

11.2 – Manually releasing and locking the gearmotor

ARIA gearmotors (models 200M/400M) are equipped with a mechanical system that allows for opening and closing the gate manually.

Manual operation must be performed in the case of a power outage or in the event of anomalies affecting the system. In case of a power outage, a back-up battery can be used (model PR100 - not supplied) (see Chapter 9 - Further information, or the relevant instruction manual).

In the event of a gearmotor fault, it is still possible to try release the motor to check whether the fault lies in the release mechanism.

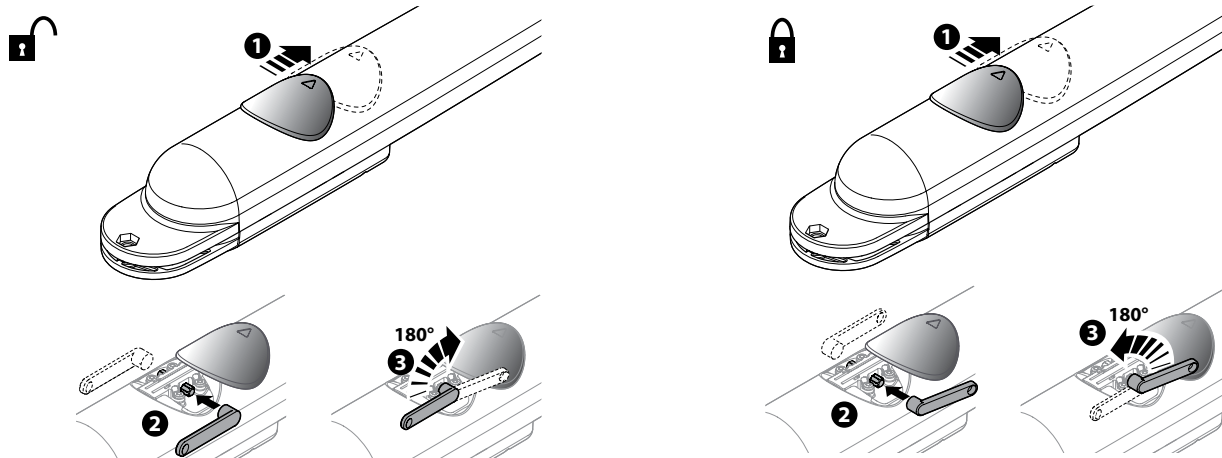

11.3 – User-admissible maintenance operations

The operations that the user must carry out periodically are listed below:

01. Disconnect the power supply.
02. Check for any deterioration in automation system components, paying special attention to erosion or oxidation of the structural parts. Replace any parts which are below the required standard.
03. Check that all screw fasteners are properly tightened.
04. Check that the nut and worm screw are adequately greased.
05. Check the state of wear of all moving parts and replace any worn components.
06. Connect the power supplies up again, and run all the tests and checks described in Chapter 5.
07. Cleaning of surfaces: use a slightly damp (not wet) cloth. Do not use substances containing alcohol, benzene, thinners or other flammable substances; the use of these substances may damage the devices and cause fires or electric shocks.

For all other equipment in the system, refer to the respective user manuals.

11.4 – Replacing the transmitter battery

If, when a key is pressed, the relevant led turns on then immediately fades and turns off, it means that the battery is completely flat and should be immediately replaced.

If instead the led turns on only for a moment, it means that the battery is partially flat; the key must be kept pressed for at least half a second for the transmitter to attempt to send the command.

⚠ Batteries contain polluting substances: do not dispose of them together with common waste but adopt the methods envisaged by the local regulations.

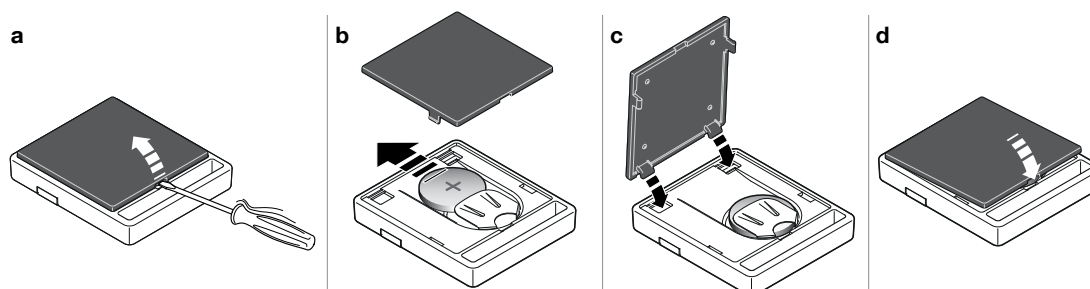

EC DECLARATION OF CONFORMITY

In conformity to Directive 2006/42/EC, ANNEX I, Part A (EC declaration of conformity for machinery)

The undersigned / company (name or company name of the subject who/that commissioned the motor-driven gate):

.....
.....

Address:

.....

Hereby declares under its/his/her sole responsibility that:

- **the automation:** motor-driven swinging gate
- **Serial N°:**
- **Year of manufacture:**
- **Location (address):**

.....

Complies with the essential requirements of the following directives:

2006/42/EC "Machines" Directive

and as provided for in the following harmonised standards:

EN 12445 "Industrial, commercial and garage doors and gates. Safety in use of Power-operated doors and gates – Test Methods"

EN 12453 "Industrial, commercial and garage doors and gates. Safety in use of Power-operated doors and gates – Requirements"

Name: Signature:

Date:

Place:

