

Look Wiring Motor 1

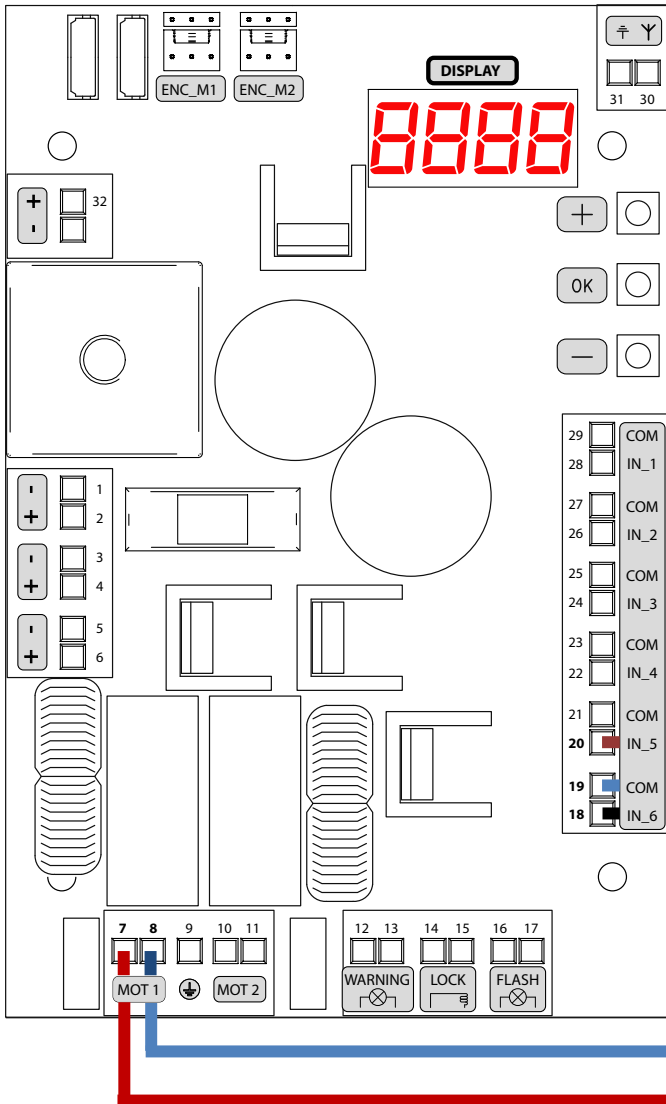

Motor 1

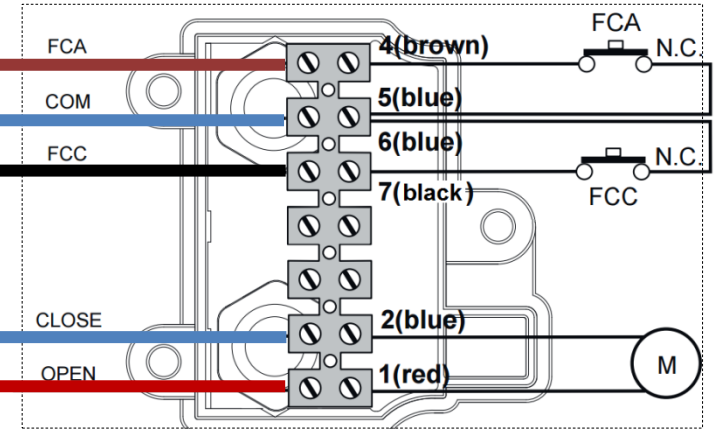

The cables are numbered

Motor 2

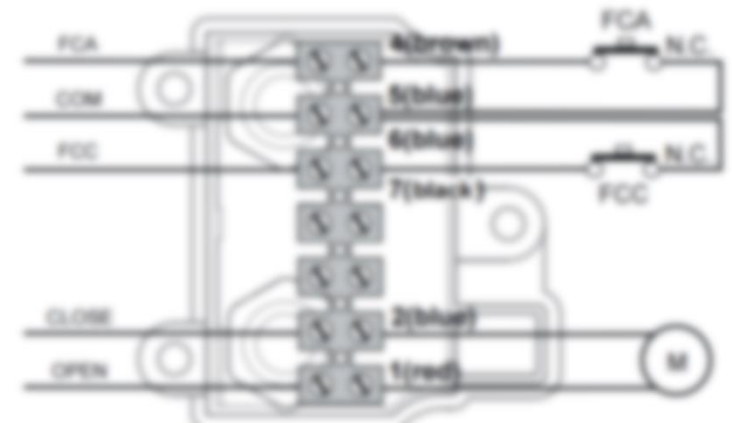

Look Wiring Motor 2

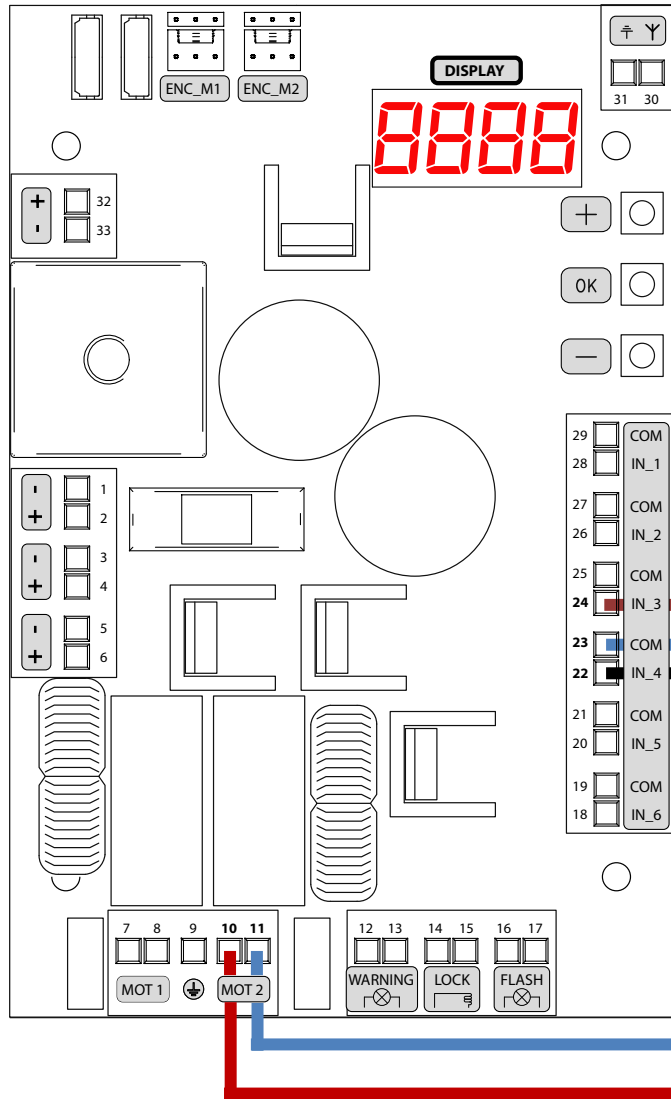

Motor 1

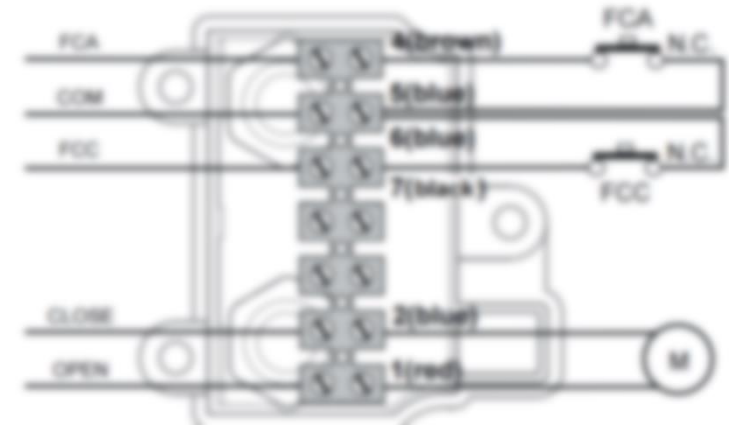

The cables are numbered

Motor 2

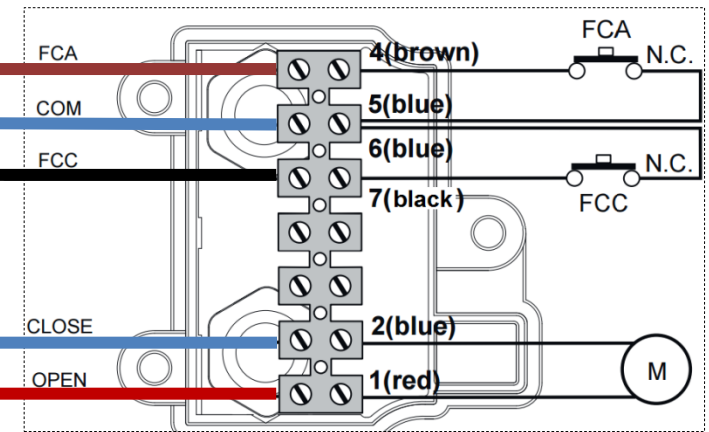

DEA Control Board Settings

Ensure NET24N is in **TYPE - 0 1**

Jumpers J5 & J9 are in Position B – “Operators without encoder”

Parameter	Value	Description
P019	0 13	Motor 2 Open Limit
P020	0 15	Motor 2 Close Limit
P021	0 12	Motor 1 Open Limit
P022	0 14	Motor 1 Close Limit
P028	00 1	“Look” Motor
P029	00 1	No Encoder(s)
P030	002	Two Motors