

Kit alimentation solaire pour motorisations de portail

FR - Instructions et avertissements pour l'installation et l'utilisation

EN - Instructions and warnings for installation and use

IT - Istruzioni ed avvertenze per l'installazione e l'uso

PL - Instrukcje i ostrzeżenia do instalacji i użytkowania

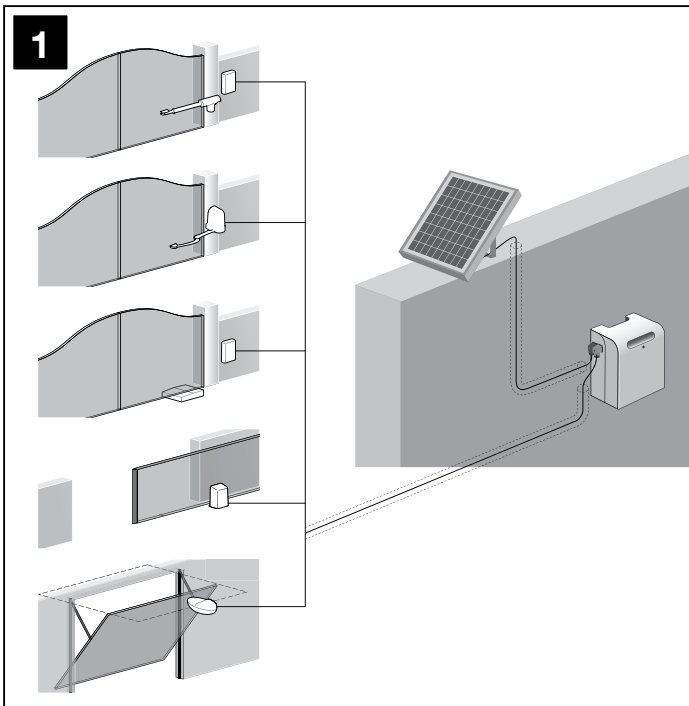

FR – SoleKIT peut être connecté à des logiques de commande différentes de la gamme Nice Home ; se reporter à la notice des logiques pour effectuer la connexion électrique.
 EN – SoleKIT can be connected to various control units in the Nice Home line; to make an electrical connection, refer to the control unit instruction manual.
 IT – SoleKIT può essere collegato a varie centrali di comando della linea Nice Home; per eseguire il collegamento elettrico vedere i manuali d'istruzione delle centrali.
 PL – SoleKIT może zostać połączony z różnymi centralami sterującymi linii Nice Home; informacje na temat podłączenia elektrycznego zawarto w instrukcjach obsługi centrali.

3 FR – Assemblage de la patte de support du panneau photovoltaïque EN – Assembly of photovoltaic panel support bracket IT – Assemblaggio della staffa di supporto del pannello fotovoltaico PL – Składanie uchwytu mocującego panelu fotoelektrycznego

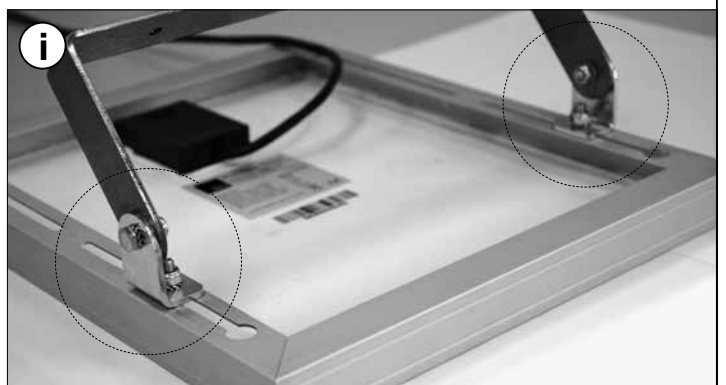
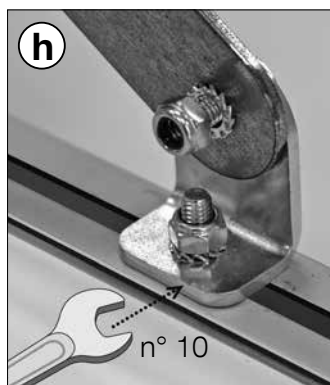
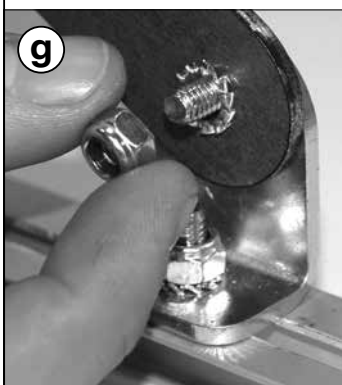
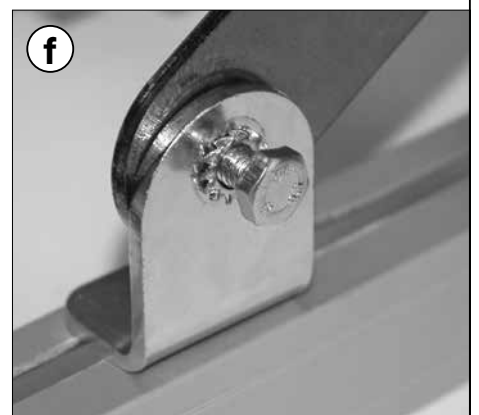
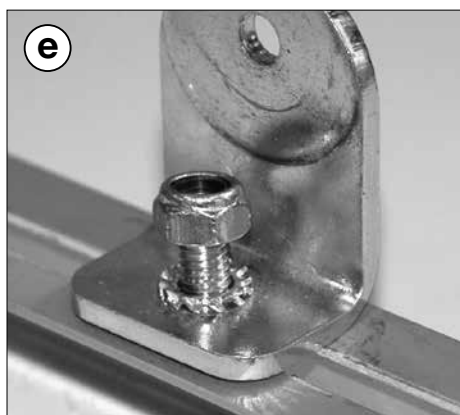
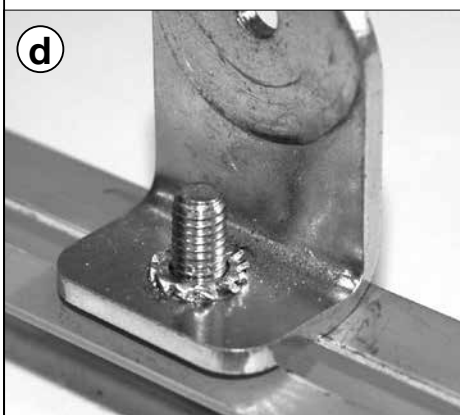
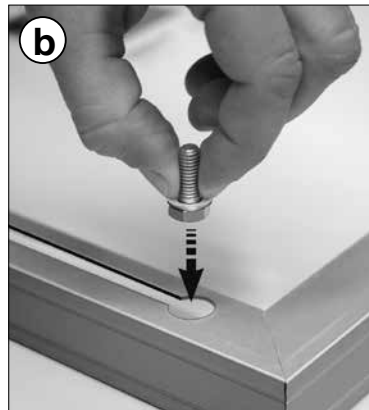

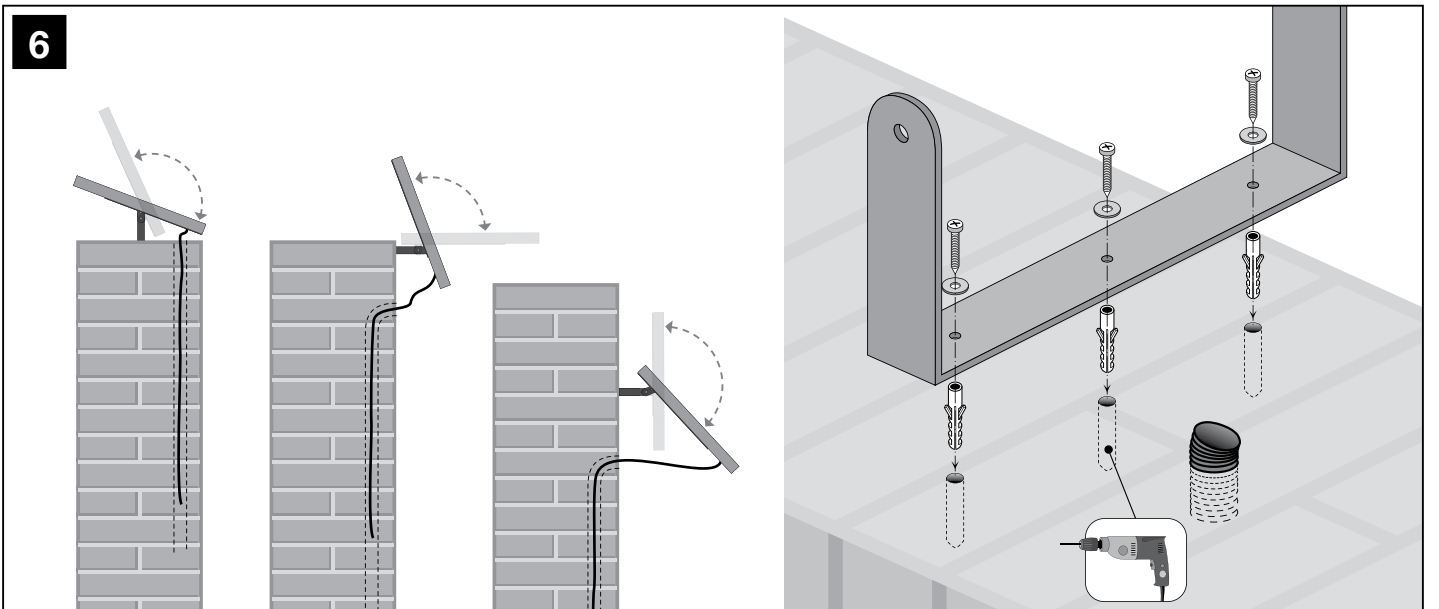
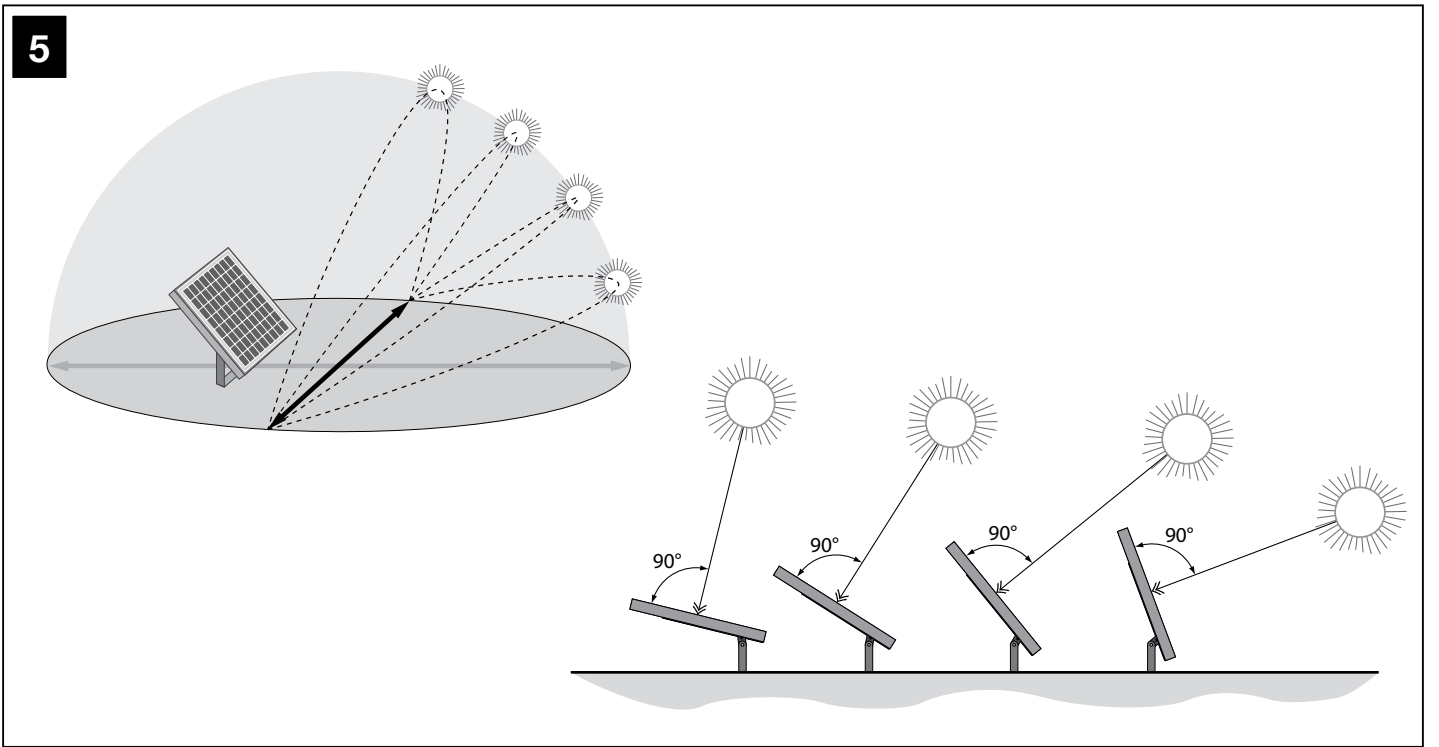
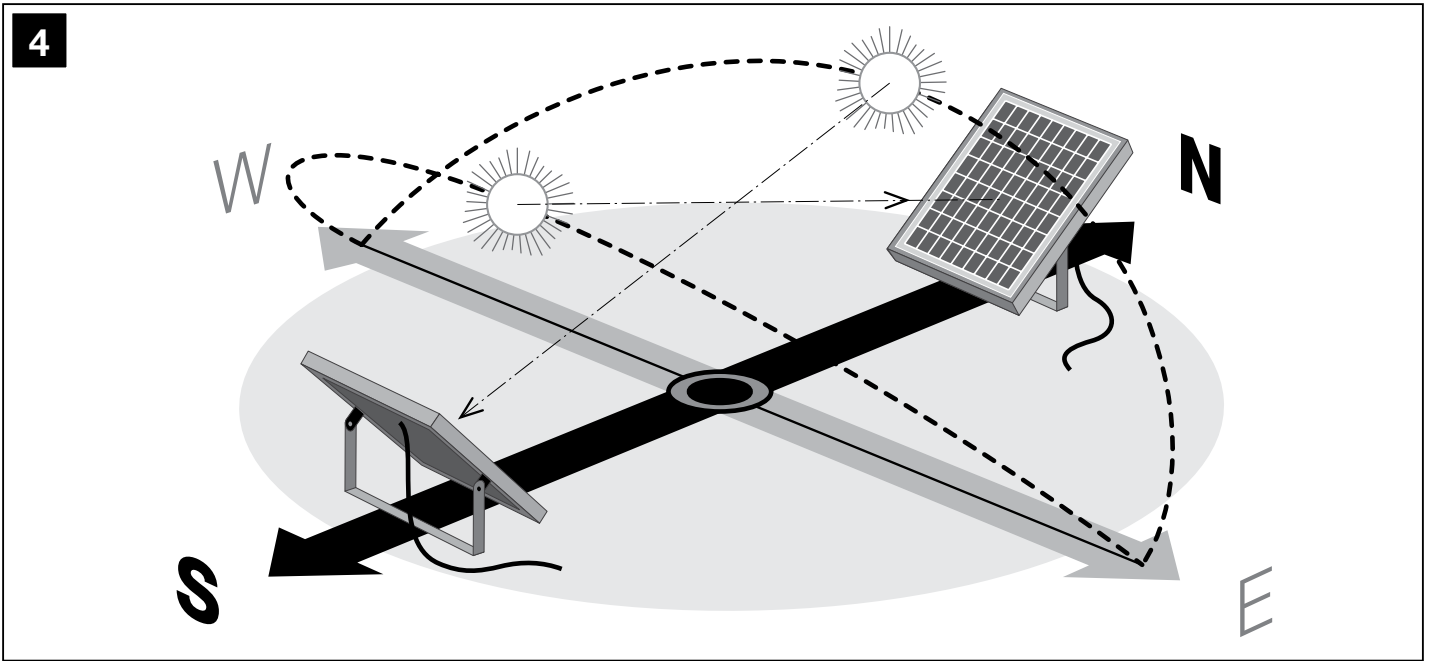

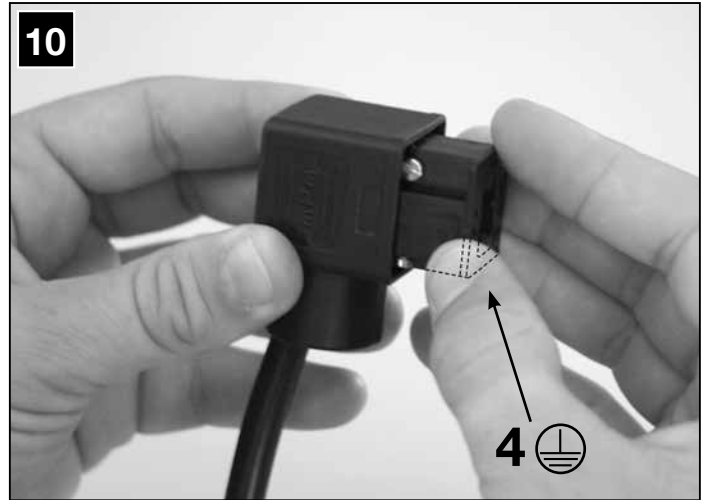
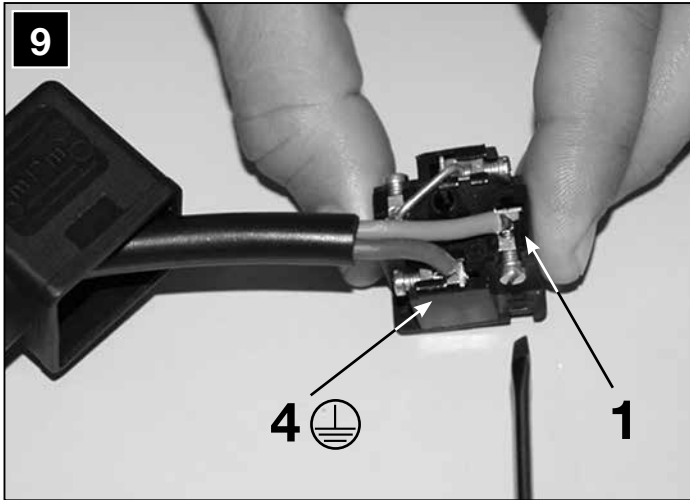
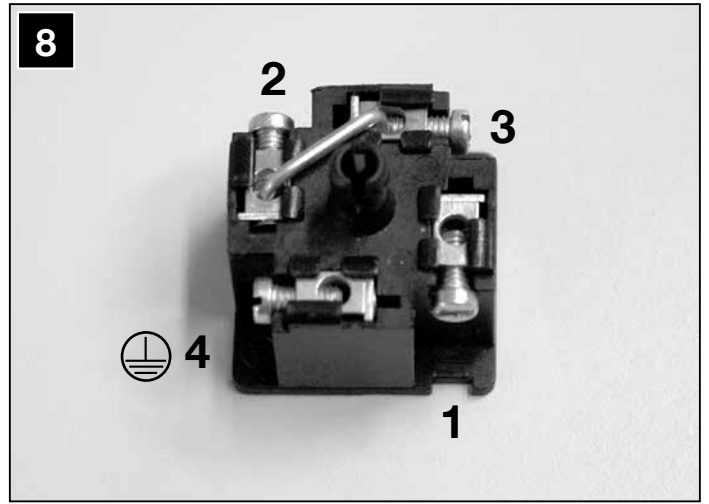
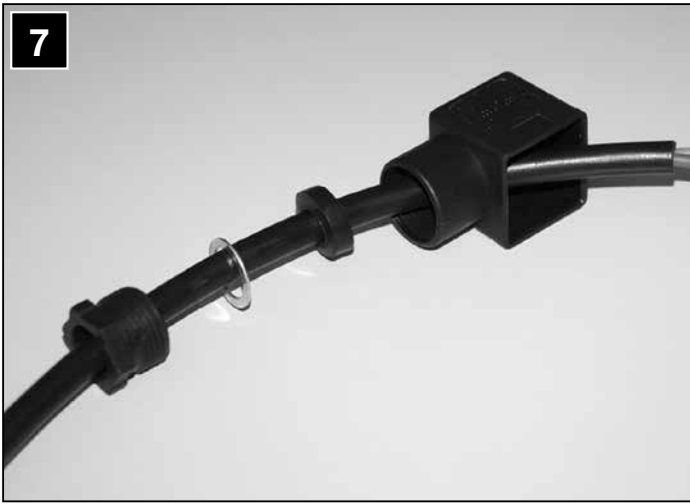

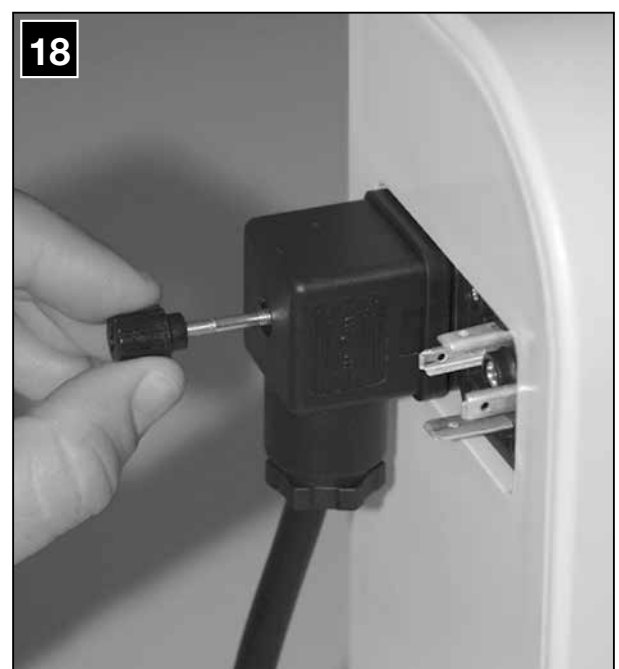
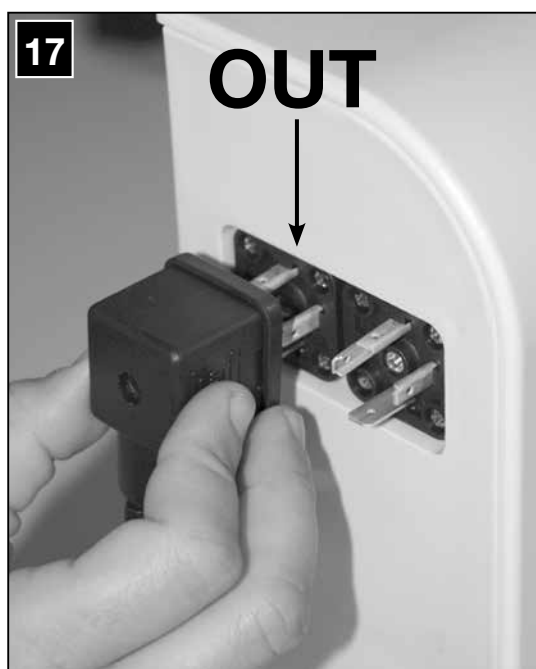
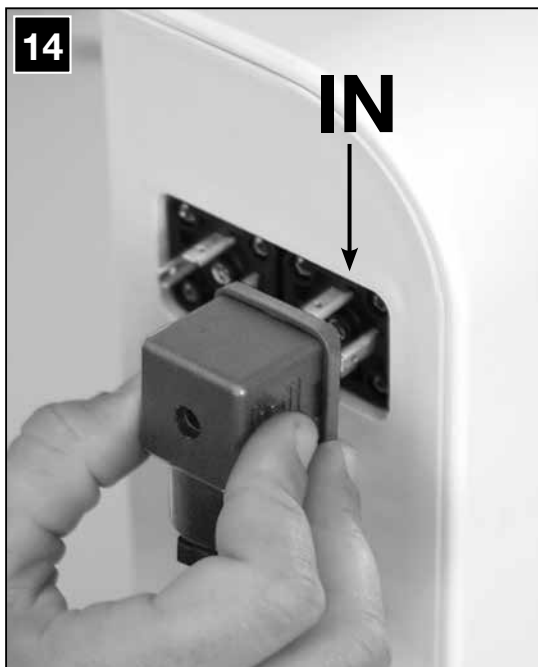
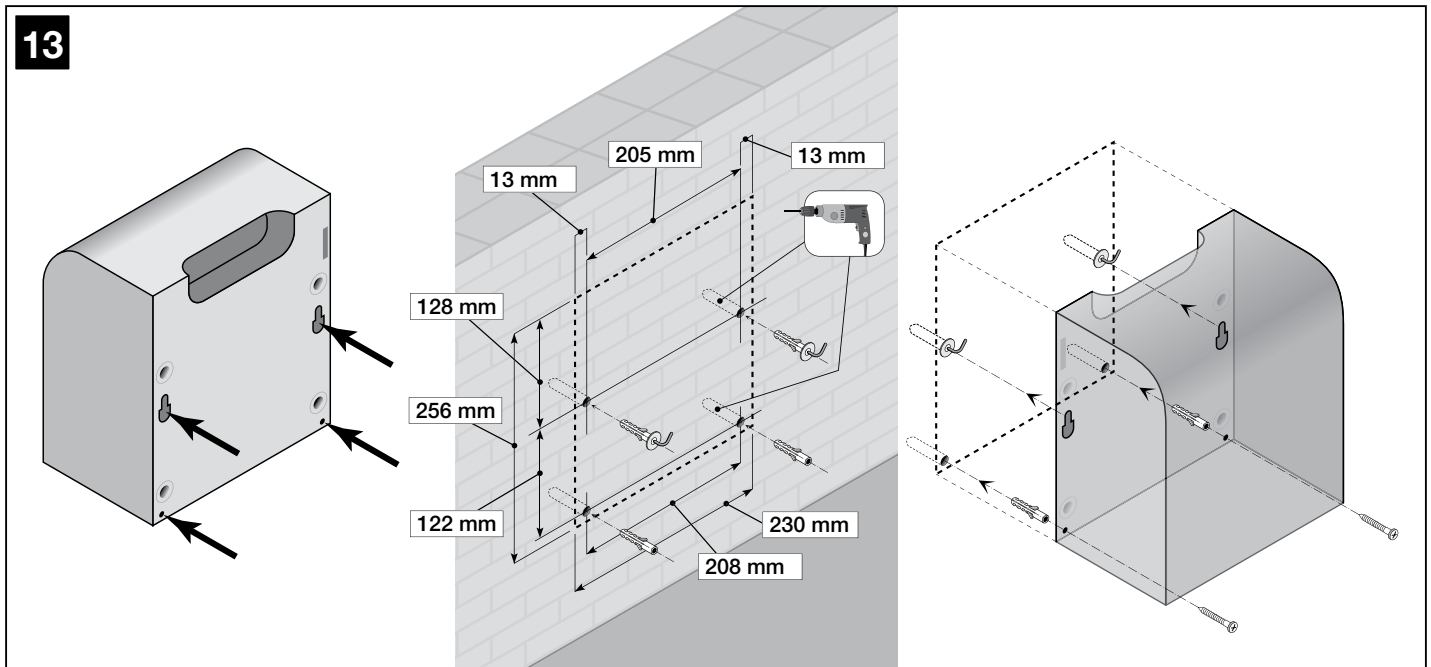

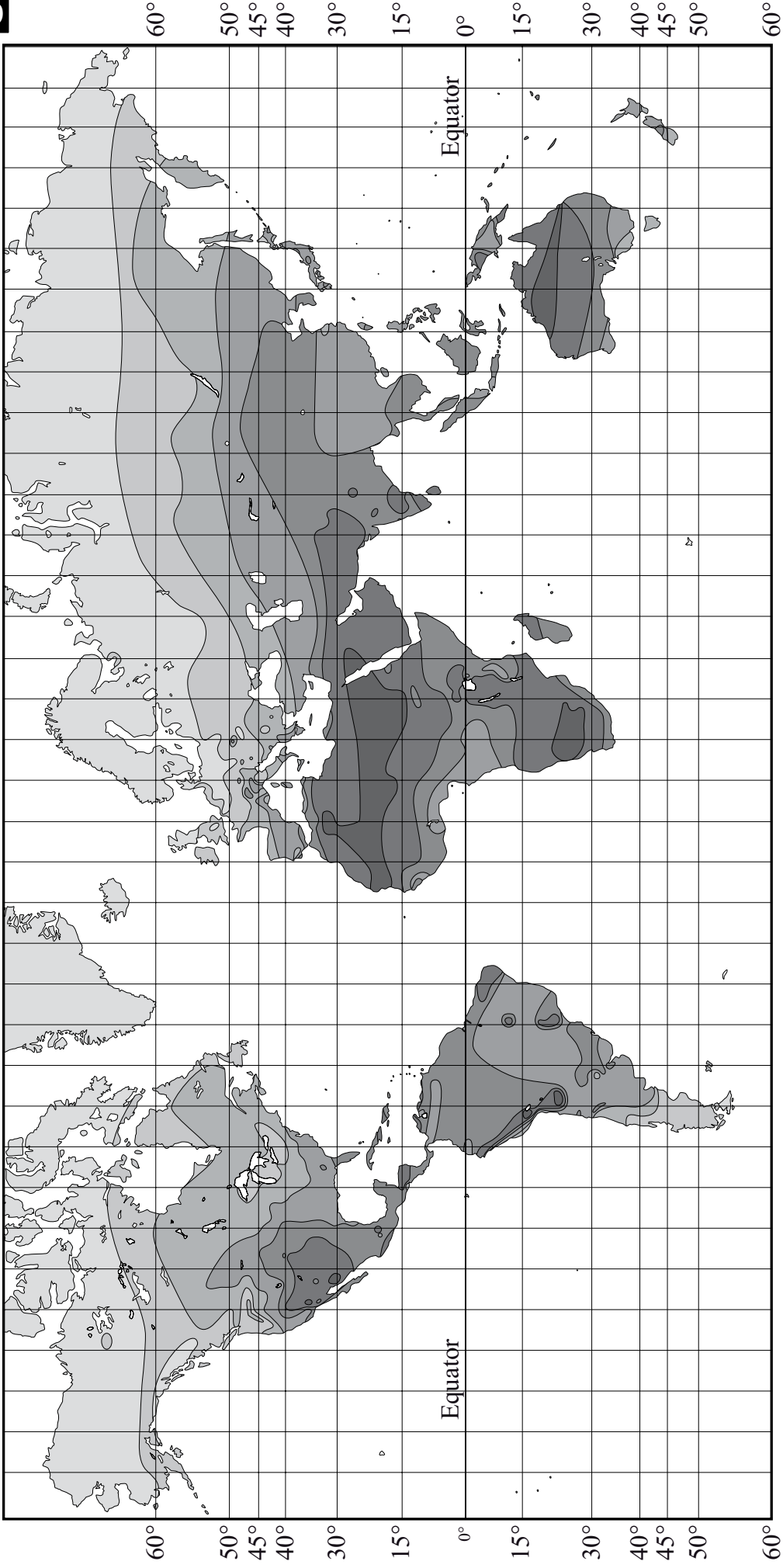

“Ea” = 5

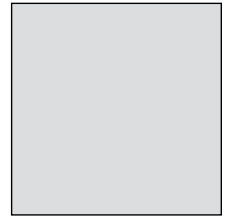

“Ea” = 10

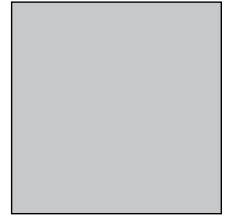

“Ea” = 12

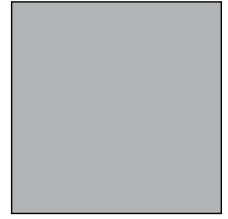

“Ea” = 14

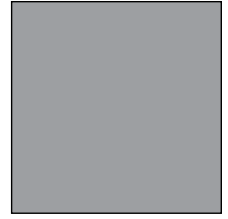

“Ea” = 16

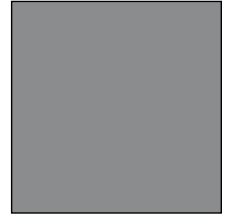

“Ea” = 18

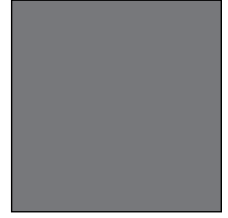

“Ea” = 20

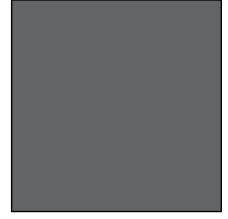

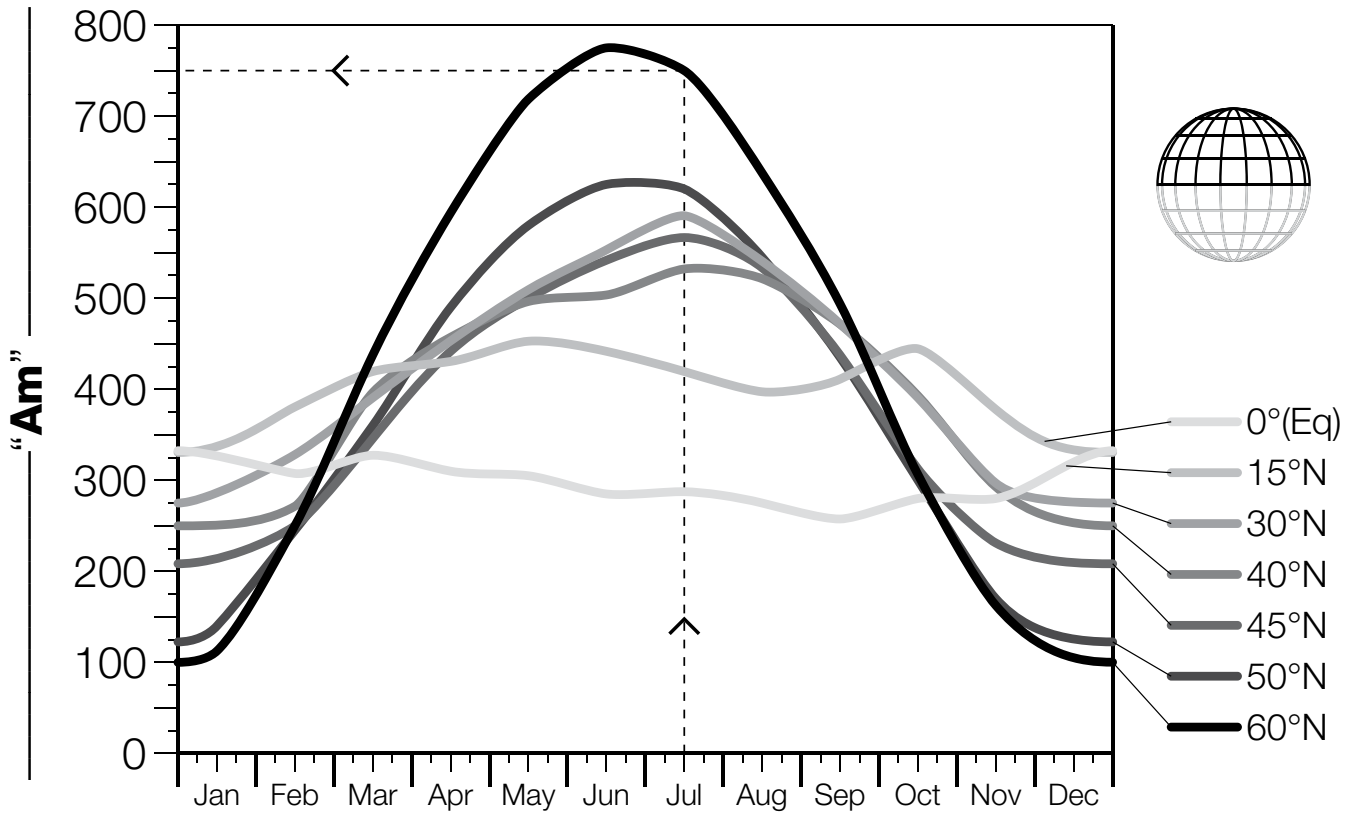
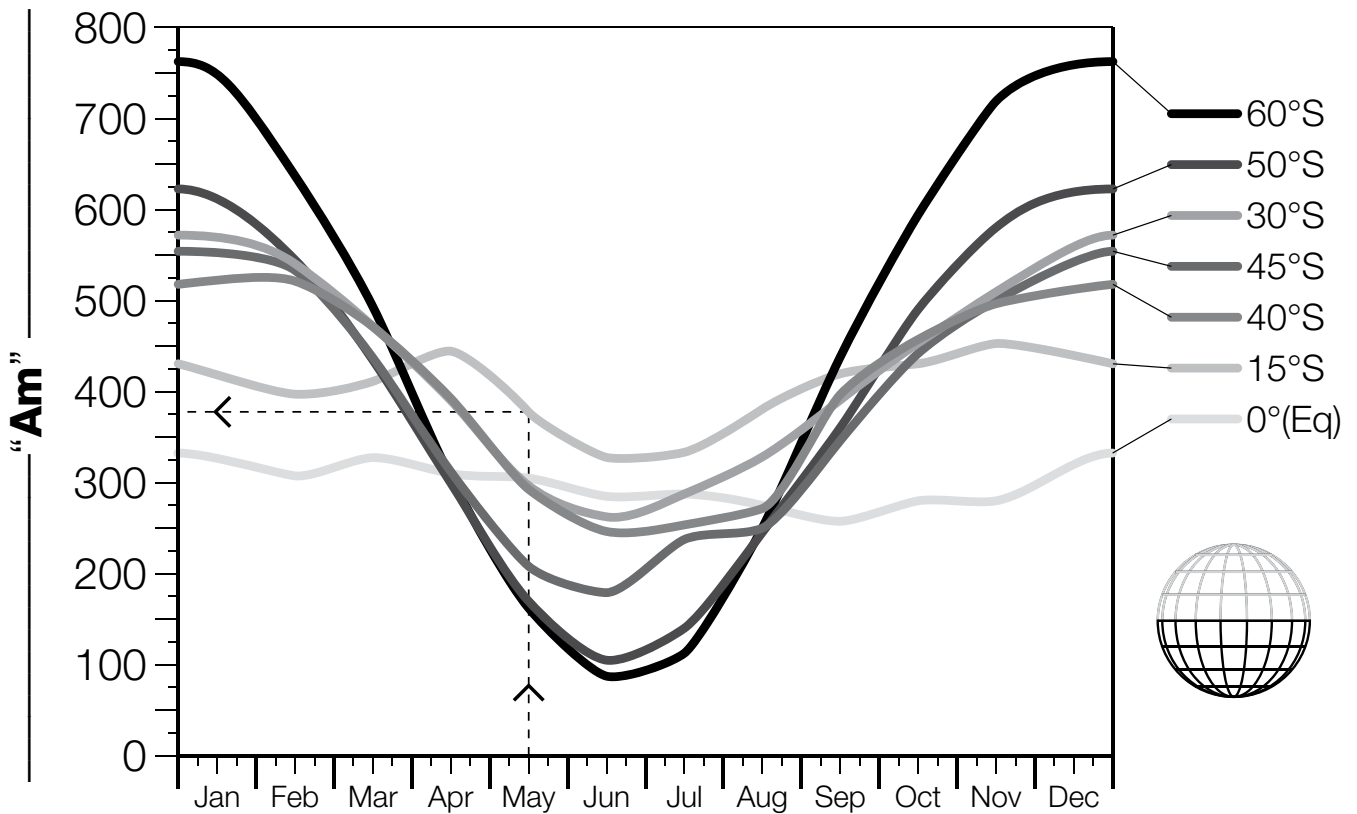
AA**BB**

GENERAL SAFETY WARNINGS AND PRECAUTIONS

The design and manufacture of the devices making up the product and the information in this manual fully comply with current standards governing safety. However, incorrect installation or programming may cause serious physical injury to those working on or using the system. For this reason, during installation, always strictly observe all instructions in this manual.

If in any doubt regarding installation, do not proceed and contact the NICE Technical Assistance for clarifications.

WORKING IN SAFETY!

Warning – for personal safety it is important to observe these instructions.

Warning – Important instructions for safety - therefore keep these instructions in a safe place to enable future product maintenance and disposal procedures.

Observe the following warnings:

– make electrical connections exclusively as envisaged in this manual incorrect: connections could cause serious damage to the system.

– The cables supplied must be used indoor and in protected environments. For use outdoors, the cables must be protected with adequate ducting.

– never touch the battery connector contacts with metal objects.

Considering the risk situations that may arise during installation phases and use of the product, the devices supplied in the pack must be installed in observance of the following warnings:

– never make any modifications to part of the devices other than those specified in this manual. Operations other than as specified can cause malfunctions. The manufacturer declines all liability for damage caused by makeshift modifications to the product.

– never place devices near to sources of heat and never expose to naked flames. This may damage system components and cause malfunctions, fire or hazardous situations.

– ensure that the devices cannot come into contact with water or other liquids. During installation ensure that no liquids penetrate the devices present.

– the product packaging material must be disposed of in full observance of current local legislation governing waste disposal.

KNOWLEDGE OF THE PRODUCT AND PREPARATION FOR INSTALLATION

CHAPTER 1 – DESCRIPTION AND INTENDED USE

SoleKIT is a solar power system designed for use with Nice Home automations for gates, garage doors, sun awnings and similar products (fig. 1).

Any other use is to be considered improper! The manufacturer declines all liability for damage resulting from improper use of the product and other than as specified in this manual.

This system uses exclusively solar power to run an automation, without the use of electrical mains power.

It can supply electrical energy continuously and permanently and can be used anywhere (for example to automate a gate situated far from the electrical mains).

The system comprises a photovoltaic panel and an electric battery:

– the **photovoltaic panel** is a device able to convert solar energy directly into electrical energy.

– the **battery** is a device that stores the electrical power produced by the photovoltaic panel during the hours of sunlight, making it available at any time of the day, including days with bad weather. A Led on the front section and an internal buzzer indicate the various charge/discharge conditions of the internal battery.

The rear of the battery is fitted with 4 holes for wall-mounting. The battery can be fixed permanently or suspended on hooks to enable future removal and transport. To facilitate transport, a handle is fitted and two separable connectors to enable quick detachment of the panel and automation.

CHAPTER 2 – COMPONENTS TO SET UP A COMPLETE POWER SUPPLY SYSTEM

Fig. 2 illustrates all components used to set up a complete power supply system. The components are:

- a)** Photovoltaic panel mod. SoleKITB;
- b)** Bracket for fixture of the photovoltaic panel;
- c)** Metal hardware (screws, washers, etc.);
- d)** Electric battery (mod. SoleKITB);
- e)** Power cable for connection between the battery and automation;
- f)** “L” type connectors;

g) Screws for “L” type socket fixture.

• Optional Accessories (not supplied in pack)

SoleKIT enables complete autonomy of system power, provided that it is used within the limits as specified in chapter 3.

If these limits are exceeded, for example due to intensive use of the automation, the energy reserve may not be sufficient.

In these cases a power supply unit is available, (model PBC2), for provisional connection to the electrical mains and rapid recharging of the battery.

CHAPTER 3 – PRELIMINARY INSTALLATION CHECKS AND PRODUCT APPLICATION LIMITS

To establish suitability of SoleKIT with respect to the automation to be powered, the checks described in this chapter must be performed.

Also check in the chapter “Product technical specifications” that the technical data of SoleKIT are suitable for the envisaged use and refer to the automation instruction manual (or addendums) to ensure that operation of the automation is envisaged with SoleKIT. **Caution!** - Simple presence of a connector for battery power supply does not imply compatibility. Products compatible with SoleKIT have been explicitly designed to reduce power consumption to a minimum when the automation is stationary, whereas a product that has not been optimised for such applications, may feature low consumption but risks excessive consumption, also when stationary, of the energy generated by the SoleKIT panel.

In the vicinity of the automation to be powered, locate the ideal point for installation of the photovoltaic panel and the battery, taking into consideration the following restraints.

- a)** the application limits specified in this chapter;
- b)** the length of the power cable (3 m) and the cable of the photovoltaic panel (3 m);
- c)** the space available in the vicinity of the automation to be powered.

Also check the following:

- d)** ensure that the selected surfaces for fixing the two devices are solid and guarantee a stable fixture.
- e)** ensure that each device to be installed is in a sheltered location

and protected against the risk of accidental impact.
f) in particular, for each device ensure the following:

Photovoltaic panel

Ensure that the selected panel installation site guarantees 100% direct exposure to direct sunlight (full sun) every day of the year. In particular, ensure that the panel installation site is far from vegetation, walls or other situations that may create shade on the panel.

Caution! – the sensitive surface must be exposed to direct sunlight in all points; partial shade, even if small in size (for example caused by a leaf or other object) will significantly reduce the power capacity of the panel.

Also, after installation, check the possibility of correctly **positioning** and **inclining** the panel, with reference to the instructions in chapter 5.

Battery

To ensure optimal efficiency of the battery and prolonged lifetime, it should be installed in a location protected against high summer temperatures and low winter temperatures.

In fact the **battery charge performance** depends on the ambient temperature where the battery is installed; optimal efficiency is ensured at around 20°C while this is reduced at temperatures below zero.

On the other hand, battery lifetime is influenced above all by high summer temperatures (above 40°C), which accelerate part ageing. Normally the average lifetime is approx. 4-5 years; this also depends on the intensity of automation use. The ideal situation is to avoid excessive discharging of the battery due to very frequent and repetitive manoeuvre cycles over periods of time.

• Application limits: Maximum possible number of cycles per day within a set period of the year

SoleKIT enables complete autonomy of the system it powers, while the average energy produced by the photovoltaic panel (which in turn is proportional to that supplied by the sun) remains above that consumed by the automation.

A simple calculation enables an estimate of the maximum number of cycles per day performed by the automation in a certain period of the year, provided that a positive energy balance is maintained.

The first part of the calculation (**energy available**) is dealt with in this chapter, the second part of the calculation (**energy consumed**, i.e. the maximum number of cycles per day) is dealt with in the respective chapter in the automation instruction manual.

Caution! - Not all automations produced by NICE are compatible with SoleKIT. If the automation instruction manual (or addendums) does not contain the chapter with the calculation of the maximum number of cycles obtainable with energy supplied by SoleKIT, this means that the automation is not compatible.

Calculating the energy available in a set period of the year

To calculate the energy available in a set period of the year, proceed as follows (the calculation already takes into account the efficiency of the photovoltaic panel and battery performance):

01. **Fig. 19** shows the average quantity of solar power radiated by the sun to the earth within one year. The 7 outlined areas show that the quantity of energy differs from zone to zone, due to a number of factors such as latitude, presence of clouds etc.
 - Therefore, in **fig. 19** read value “**Ea**” of the average annual energy, available in your geographical area, as well as the degrees of **latitude** of your geographical location.
02. As well as the measured value “Ea”, the variable progress of energy available in the various periods of the year must be taken into account with reference to the specific zone. In fact, the quantity of energy varies (increases/decreases) according to the seasons (see the curves in **graphs AA** and **BB**): in the months with more exposure to sunlight (summer) much more energy is available with respect to winter months; this difference is less evident in the zones closer to the equator and more accentuated in the zones closer to the terrestrial poles.
 - Therefore, to calculate the lowest number of manoeuvre cycles per day, refer to **graph AA** (for zones north of the equator) or **graph BB** (for zones south of the equator) and select

the curve related to your latitude and the period of the year with least exposure to sunlight (corresponding to the lowest point of the curve). Then cross reference the two values, as shown in the example on the graph, to obtain the value “**Am**” (radiation within a set period).

03. Then calculate the value “**Ed**”, i.e. the energy available in your zone within the set period of the year, multiplying the values as follows: **Ea x Am = Ed**.
04. Lastly, to calculate the **maximum possible number of cycles per day, for the selected period**, calculate using the value “**Ed**” obtained (energy available) according to the instructions in the specific chapter of the automation instruction manual.

Warning – During the day, if the photovoltaic panel remains in the shade for a certain period of time (in particular from 10 am to 2 pm) the energy available decreases in proportion to the hours without panel exposure to sunlight.

CHAPTER 4 – BATTERY DISCHARGE

The previous chapter describes how to calculate the maximum number of automation cycles per day. This is an estimate based on the average energy available within the period of one year. In the event of long periods of particularly adverse weather conditions or when more manoeuvres are required than those usually admitted, the stored energy may run out.

When this occurs, the led on the battery indicates the battery discharged status with one flash at regular intervals (approx. 5 seconds) and beeps emitted in time with the Led: this signal may be temporary or permanent. In both cases, the battery must be recharged according to one of the following procedures:

A) rapid recharge of battery using power supply unit mod. PBC2 (optional accessory);

B) limit use of the automation until the weather conditions improve and enable recharging of the battery via the photovoltaic panel. In both cases, the “battery discharged” warning is cleared when the system reaches sufficient electrical autonomy to enable automation operation.

CHAPTER 5

STEP 1 – Assembly of photovoltaic panel support bracket

Assemble all components of the support bracket on the rear of the panel, as shown in **fig. 3**.

Caution! – The bracket at the rear of the panel must be positioned (**fig. 3-b**) according to the type of position in which the panel is mounted. To select the position, refer to **fig. 6**.

STEP 2 – Photovoltaic panel positioning

Caution! – For optimal operation of the panel, it must be positioned precisely in the selected location. Therefore, after performing the checks as described in chapter 3, strictly observe the following instructions: as a general rule, the panel must be positioned so that it can receive the maximum possible sunlight during the day and throughout the year. This means that its horizontal position and vertical angle must be calculated on the basis of the location where it is to be installed.

• **Ensure the correct position of the panel on the horizontal plane** as follows:

- a) In the installation site, determine the cardinal points **NORTH** and **SOUTH**, with the aid of a compass or a geographical map of the location.
- b) Then position the panel in the direction **NORTH** or **SOUTH**, according to the following:
 - if the installation site is **in a country North of the equator** (United States; Europe; Russia; etc.) the panel must be positioned **exactly SOUTH**;
 - if the installation site is **in a country South of the equator** (Latin America; Australia; Indonesia, etc.) the panel must be positioned **exactly NORTH**.

For further information, refer to **fig. 4**.

• **Ensure the correct position of the panel on the vertical plane** as follows:

Considering that it is preferable to ensure maximum efficiency of the panel during the winter period, when there is less energy available than in the summer, the panel should be positioned at an angle that ensures reception of the sun rays perpendicular (from front) to the sensitive surface.

This angle corresponds to the latitude of the location and can be read on any commercial geographical map. For example, Madrid has a latitude of 40°; Venice 45°; or London approx 50° etc. For further information, refer to **fig. 5**.

STEP 3 – Fixing the photovoltaic panel in the selected site

After establishing the precise position of the panel, fix to the selected surface as shown in **fig. 6**.

STEP 4 – Fixing the battery in the selected site

After performing the checks as described in chapter 3 and establishing the precise position of the battery, fix to the selected surface as shown in **fig. 13**. **Note** – use the 2 lower screws only if you wish to anchor the battery in a permanent position, i.e. when removal is not required.

STEP 5 – Cable routing

IMPORTANT! – The cables supplied must be used in indoor and protected environments. For use outdoors, the cables must be protected with adequate ducting.

After fixing the panel and battery, route the panel cable through the tube or protection ducting through to the battery.

With reference to the instruction manual of the automation to be powered, remove the control unit protection cover. Then pass the end of the power cable (with wires exposed) through the automation

(where the other cables are routed). Then route the cable through the protection ducting (if present) through to the battery.

Caution! – Do not connect the power cable to the control unit; leave access to the control unit open.

STEP 6 – Assembly of “L” socket on the photovoltaic panel cable

If the cable is too long, it can be shortened, taking care to strip the wires so that their length is equal to the values specified in the **fig. 20** (**caution!** – different lengths may impair subsequent assembly of the socket).

Then proceed with assembly of the **GREY** “L” type socket on the end of the panel cable, as follows:

01. Insert the various elements of the socket on the cable, taking care to observe the sequence as shown in **fig. 7**;

CAUTION! – Do not modify the electric jumper on the connector (**fig. 8**).

02. Using a slotted screwdriver, attach the **blue wire to terminal n° 1** on the connector and the **brown wire to the earthing terminal (4)** (**fig. 9**):

Note – The reference numbers and symbols are printed on the connector below the terminals and on the opposite side.

03. After fixing the two wires, insert the connector in its casing (**fig. 10**).

Important – The correct position of the connector is that with the earthing symbol in the lower position (see **fig. 10**);

04. Then pull the cable outwards from the socket and insert the seal and washer (**fig. 11-a-b**). Lastly, tighten the cable clamp (**fig. 11-c**) using a wrench, to guarantee completely sealed closure.

05. After assembling the socket, position the seal supplied on the connection side (**fig. 12**).

STEP 7 – Assembly of “L” socket on the power cable

If the cable is too long, it can be shortened, taking care to strip the wires so that their length is equal to the values specified in the **fig. 20** (**Caution!** – different lengths may impair subsequent assembly of the socket).

Then proceed with assembly of the **BLACK** “L” type socket on the end of the power cable, as follows:

01. Insert the various elements of the socket on the cable, taking care to observe the sequence as shown in **fig. 7**;

CAUTION! – Do not modify the electric jumper on the connector (**fig. 8**).

02. Using a slotted screwdriver, attach the **blue wire to terminal n° 1** on the connector and the **brown wire to the earthing terminal (4)** (**fig. 9**):

Note – The reference numbers and symbols are printed on the connector below the terminals and on the opposite side.

03. After fixing the two wires, insert the connector in its casing (**fig. 10**).

Important – The correct position of the connector is that with the earthing symbol in the lower position (see **fig. 10**);

04. Then pull the cable outwards from the socket and insert the seal and washer (**fig. 11-a-b**). Lastly, tighten the cable clamp (**fig. 11-c**) using a wrench, to guarantee a completely sealed closure.

05. After assembling the socket, position the seal supplied on the connection side (**fig. 12**).

STEP 8 – Connecting the photovoltaic panel to the battery

To connect the panel to the battery, proceed as follows:

01. Connect the **GREY** “L” type socket to the “**IN**” connector on the battery (**fig. 14**);

02. To select the most suitable connection configuration for the

connection of all system devices, refer to the example shown in **fig. 15. Note** – If frequent disconnection of the battery plug is envisaged, use the screw in **fig. 16-a**. Otherwise use the screw in **fig. 16-b**.

Caution! - When the battery is recharging via the photovoltaic panel, the red led emits 2 short flashes every 5 seconds. Therefore check that this signal is present when the panel is exposed to the sunlight.

STEP 9 – Connecting the battery to the automation

To connect the battery to the automation, proceed as follows:

01. Connect the **BLACK** “L” type socket to the “**OUT**” connector on the battery (**fig. 17**);
02. To select the most suitable connection configuration for the connection of all system devices, refer to the example shown in **fig. 18. Note** – If frequent disconnection of the battery plug is envisaged, use the screw in **fig. 16-a**. Otherwise use the screw in **fig. 16-b**.
03. Access the control unit of the automation and insert the power cable connector in the buffer battery socket on the control unit. To locate this socket, refer to the instruction manual of the automation to be powered.

Caution! - when the automation is powered by SoleKIT, it must **NEVER BE POWERED** via the mains at the same time.

— General note —

IMPORTANT – After connecting the product to the automation, the system may not be operative immediately; this depends on the fact that the battery may be discharged due to the natural process of discharging over time, even when stored. In this case, there are two ways to proceed:

A) Disconnect the battery from the automation control unit and wait for a few days for the photovoltaic panel to receive sufficient sunlight in order to recharge the battery;

B) Proceed with rapid recharge of battery using back-up power supply unit mod. PBC2 (optional accessory).

— Visual and audible signals —

The SoleKIT is equipped with a led and a buzzer.

- When the battery is recharging (via the photovoltaic panel or battery charger) the red led emits 2 short flashes every 5 seconds. Therefore check that this signal is present, also after installation, when the panel is exposed to the sunlight.
- When the battery has completed charging via the battery charger, the led remains permanently lit.
- When the battery is discharged, the red led emits one short flash every 5 seconds, accompanied by a beep.

— Notes for use —

- **NEVER leave the battery connected to the automation if the photovoltaic panel is not also connected and operational.**

Caution! - If the battery is not sufficiently recharged, the reserve will run out within a few days.

- **If the automation is not used for prolonged periods, detach the connectors of the automation and photovoltaic panel from the battery and store the latter in a cool and dry location.**

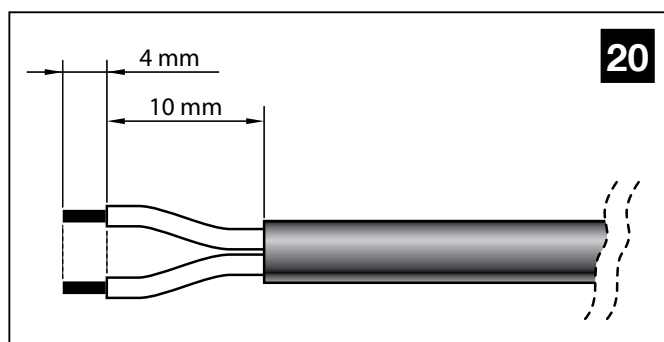

WHAT TO DO IF... (troubleshooting guide)

- **The automation control unit does not turn on and the led remains off.**

This may be caused by incorrect connections or electric wires not fully inserted. Otherwise the battery may be totally discharged, in which case no signal can be sent: in this case a rapid recharge is required by means of power supply unit (mod. PBC2) or wait for the photovoltaic panel (connected correctly) to recharge the battery.

- **The battery tends to discharge too quickly.**

This may depend on excessive ageing of the battery, in which case it should be replaced; otherwise it may be due to excessively intensive use of the automation, over the application limits envisaged in this manual, found in chapter 3.

Otherwise the automation may not be compatible for operation with SoleKIT, or the automation is incorrectly configured for low consumption, or too many accessories are connected.

- **The battery no longer recharges.**

This may be due to a malfunction of the photovoltaic panel caused by incorrect installation, incorrect cable connections, or malfunction of the battery.

PERIODIC MAINTENANCE OPERATIONS

In general, this product does not require special maintenance; however, regular checks over time will ensure system efficiency.

Therefore, to ensure correct maintenance, check every 6 months that the photovoltaic panel has not accumulated dirt (leaves, sand, etc.) as this may reduce efficiency.

Also check whether battery replacement is required, as the ageing process reduces autonomy over time.

Take into account that battery lifetime is influenced above all by high summer temperatures, which accelerate part ageing. Normally the average lifetime is approx. 4-5 years; this also depends on the intensity of automation use: The ideal situation is to avoid excessive discharging of the battery due to very frequent and repetitive manoeuvre cycles over periods of time.

CAUTION – The battery must be replaced exclusively by skilled and qualified personnel.

DISPOSAL

Product disposal

This product is an integral part of the automation and therefore must be disposed together with the latter.

As in installation, also at the end of product lifetime, the disassembly and scrapping operations must be performed by qualified personnel. This product comprises various types of materials: some may be recycled others must be disposed of. Seek information on the recycling and disposal systems envisaged by the local regulations in your area for this product category.

Caution! – some parts of the product may contain pollutant or hazardous substances which, if disposed of into the environment, may cause serious damage to the environment or physical health.

As indicated by the symbol alongside, disposal of this product in domestic waste is strictly prohibited. Separate the waste into categories for disposal, according to the methods envisaged by current legislation in your area, or return the product to the retailer when purchasing a new version.

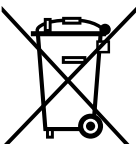

The product also contains a lead battery, i.e. an element that is highly pollutant if not disposed of correctly. The battery must be removed and disposed of as specified in the paragraph "Battery disposal".

Caution! – Local legislation may envisage serious fines in the event of abusive disposal of this product.

Battery disposal

Caution! – The battery contains pollutant substances and therefore must NEVER be disposed of in common waste collection points after removal. Dispose of or recycle according to current local standards.

TECHNICAL SPECIFICATIONS OF PRODUCT COMPONENTS

WARNINGS: • The product SoleKIT is produced by Nice S.p.a. (TV) I. • All technical specifications stated herein refer to an ambient temperature of 20°C (± 5°C)
 • Nice S.p.a. reserves the right to apply modifications to the product at any time as deemed necessary, while maintaining the same functionalities and intended use • The estimated minimum number of manoeuvres per day, is applicable exclusively with the photovoltaic panel positioned correctly and in the conditions as specified in chapter 3 under the heading "Application Limits".

SoleKITB BATTERY

DESCRIPTION	DATA
Rated voltage:	24 V $\overline{\text{---}}$
Maximum current:	10 A
Rated battery capacity:	20 Ah
Protection rating:	IP 44
Operation temperature:	from -20°C to +55°C (when charging using the back-up power supply unit: from 0°C to +40°C)
Complete recharging time:	approx. 15 hours (when using the back-up power supply unit)
Dimensions:	258 mm x 235 mm x 180 mm
Weight:	14 kg

Note – The batteries used on SoleKITB are type VRLA, "Valve Regulated Lead Acid Batteries", i.e. sealed and valve-controlled, compliant with the specific provision A67 of the IATA/ICAAO Regulation governing hazardous products. SoleKITB and SoleKIT are therefore not considered hazardous goods and may be transported without any risk by air, sea and on road.

SoleKITB PHOTOVOLTAIC PANEL

DESCRIPTION	DATA
Rated voltage:	24 V $\overline{\text{---}}$
Maximum power:	10 W
Operation temperature:	from -40°C to +85°C
Dimensions:	354 mm x 290 mm x 28 mm
Weight:	1,4 kg

Warning – The glass of the photovoltaic panel has been tested to resist to hailstones and medium entity impact (resistant to impact with a steel sphere of 227 g, falling from a height of 1 metre). In the event of particularly consistent hail or impact, the glass may be damaged; in this case contact the NICE Technical Assistance service.

CE DECLARATION OF CONFORMITY

Declaration in accordance with the following Directives: 2014/35/UE (LVD) and 2014/30/UE (EMC)

*Note – The content of this declaration corresponds to that specified in the official document deposited at the Nice S.p.A. headquarters and, in particular, to the latest revised edition available prior to the publishing of this manual. The text herein has been re-edited for editorial purposes.
 A copy of the original declaration can be requested from Nice S.p.A. (TV) Italy.*

Declaration number: 570/SUN

Revision: 0

Language: EN

Manufacturer's Name: NICE S.p.A.

Address: Via Pezza Alta 13, 31046 Rustignè di Oderzo (TV) Italy

Type of product: Solar power kit for gate automatisms

Model/Type: SOLEKIT

Accessories: SOLEKITC, SOLEKITB, PBC2

The undersigned Roberto Griffa, as Chief Executive Officer, hereby declares under his own responsibility that the product identified above complies with the provisions of the following directives:

- DIRECTIVE 2014/35/EU OF THE EUROPEAN PARLIAMENT AND OF THE COUNCIL of 26 February 2014 on the harmonisation of the laws of Member States relating to the making available on the market of electrical equipment designed for use within certain voltage limits (recast), according to the following harmonised standards:
 EN 60335-1:2002 + A1:2004 + A11:2004 + A12:2006 + A2:2006 + A13:2008+A14:2010+A15:2011
- DIRECTIVE 2014/30/EU OF THE EUROPEAN PARLIAMENT AND OF THE COUNCIL of 26 February 2014 on the harmonisation of the laws of the Member States relating to electromagnetic compatibility (recast), in accordance with the following harmonised standards: EN 61000-6-2:2005, EN 61000-6-3:2007+A1 :2011

Oderzo, 28 July 2016

Ing. **Roberto Griffa**
 (Chief Executive Officer)

